

BLOCK CYLINDER
DOUBLE POWER

PBL Series

테이블 이송형 구조



강력한 추력과 안정적인 구조

- 2본의 실린더 적용으로 2배의 추력 발휘
- 2본의 가이드 축의 광폭 배치로 롤링 모멘트 대응력 확대로 안정적인 가이드 구조 적용

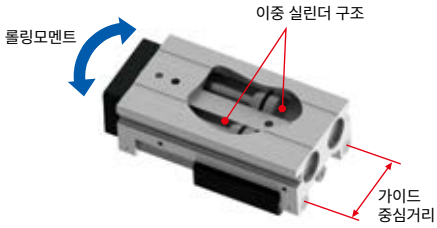

실린더 경	이론추력(kgf) (압력 5kgf/cm ² 기준)		가이드 중심 거리 (mm)	
	전진	후진	PBL	PB
Ø6	2.85	2.1	24	-
Ø8	5	3.75	29	-
Ø12	11.3	8.5	37	20
Ø16	20.1	15.1	45	26
Ø20	31.4	23.55	53	30
Ø25	49.05	37.8	66	39

고정도, 고강성 사양

- 볼부시 2개를 직렬 배치하여 가이드 구간 확대
- 자사 블록 실린더 대비 고정도의 주행 평행도 실현
- 테이블 두께의 보강으로 고강성 확보



- PBL12-50
테이블 높이 정도(후진): **0.1mm**
전후진 주행 평행도: **0.15mm**

- 보충 수치가 아니며 참고 수치입니다.
- 상기 수치는 압력 5kgf/cm² 기준이며 실린더경과 스트로크에 따라 상이합니다.

사용자 편의 증대

- 사용자 취부 탭과 위치 결정용 홀의 충분한 깊이 제공
- 에어포트와 센서홀을 대칭 적용

탭 깊이 최소
탭 직경의 **1.5배** 이상 제공



핀 홀 깊이 최소 핀 직경의
1배 이상 제공

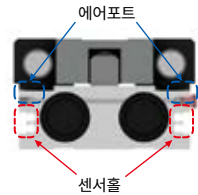

※ 플러그는 한쪽만 제공해 드립니다.
탈착후 사용하시는 에어포트 반대
편쪽으로 조립하세요.

다양한 Stopper 제공

- Urethane Stopper, Shock Absorber 옵션 장착 가능
- 스톱퍼를 별도의 브라켓 없이 테이블에 바로 장착 가능
- 스톱퍼를 중앙에 배치함으로 위치 정도 향상



다양한 취부 방식 제공

워크 취부

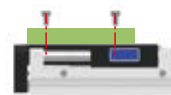

테이블 탭 이용



플레이트 탭 이용

몸체 취부



몸체 관통홀 이용



몸체 탭 이용

BLOCK CYLINDER

PBL Series

특징

NEW

- 2분의 실린더를 병렬로 배치시킨 Twin 실린더 구조로 2배의 추력 발휘
- 가이드 축 간 중심 거리를 광폭 배치하여 우수한 모멘트 대응력 발휘
- 직렬 구조의 더블 볼부시 적용으로 우수한 주행 평행도 실현
- 테이블의 두께 보강으로 충분한 탭 깊이와 고강성 실현
- 테이블 구조와 전면 플레이트 배치로 사용자 편의성 확보
- 에어포트와 센서홀을 양측으로 제공하여, 대칭형 제품 선정 불필요
- 전시리즈 전진단 Urethane Stopper 기본 장착, Shock Absorber 옵션 선택 장착 가능
- 위치검출용 Auto Switch 장착 가능



주문형식

PBL 12 - 30 - E - ST - A2 L S

① ② ③ ④ ⑤ ⑥ ⑦ ⑧

① 기본형식

② 실린더경

기 호	실린더경(mm)	기 호 (=표준행정(mm))
06	6	10, 20, 30, 40, 50
08	8	10, 20, 30, 40, 50
12	12	10, 20, 30, 40, 50, 75
16	16	10, 20, 30, 40, 50, 75
20	20	10, 20, 30, 40, 50, 75, 100
25	25	10, 20, 30, 40, 50, 75, 100

③ 표준행정

④ 특수 사양

기 호	특수 사양
무기호	일반 사양
E	2차전지 사양

⑤ Stroke 조절 Stopper 사양

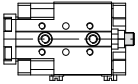
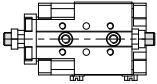
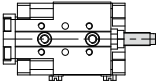
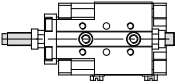
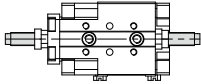
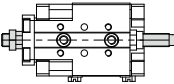
무기호	ST	SHF	SHB	SH2
전진단 Urethane Stopper	전진단 Urethane Stopper 후진단 Urethane Stopper	전진단 Shock Absorber	전진단 Urethane Stopper 후진단 Shock Absorber	전진단 Shock Absorber 후진단 Shock Absorber
				
SHT 전진단 Shock Absorber 후진단 Urethane Stopper				

※ 상기 내역 외 Stopper 구성이 필요할 경우, 본사로 연락 바랍니다.

사 양

형 식		PBL06	PBL08	PBL12	PBL16	PBL20	PBL25
실린더경(mm)		2×6	2×8	2×12	2×16	2×20	2×25
로드경(mm)		3	4	6	8	10	12
표준행정(mm)		10 ~ 50	10 ~ 50	10 ~ 75	10 ~ 75	10 ~ 100	10 ~ 100
이론추력(kgf)	전진	0.57×P	1×P	2.26×P	4.02×P	6.28×P	9.81×P
	후진	0.42×P	0.75×P	1.7×P	3.02×P	4.71×P	7.56×P
P : 사용공기압(kgf/cm ²)							
배관접속구		M3			M5		
사용유체					청정공기 주1)		
사용압력(kgf/cm ²)					3 ~ 7 (보종 내압력 : 10.5) 주2)		
사용윤활					불필요 (급유시 터어빈오일 1종 ISOVG 32)		
사용온도(°C)					5 ~ 60		
사용속도(mm/sec) 주3)					50 ~ 300		
작동방식					복동형		
반복위치정도(mm)					± 0.04		
전진시Stroke허용공차(mm)					0 ~ +1		

주1) 청정공기 : 3~10 μ m의 여과도를 거친 99.9%의 액상 유분 및 과포화 수분 0.3%의 고형물질을 함유하는 청정도의 공기

주2) 보종 내압력 : 무부하 상태로 1분간 상기압력을 가압 했을때 부품에 이상이 발생되지 않는 압력

주3) 사용가능 속도는 부하의 크기, 부하중심의 위치, 취부방법에 따른 기중선정 방법의 산출 결과를 통해 상기 범위내에서 사용 가능 합니다.

본체 중량

단위 : kgf

Model	Stroke (mm)	10	20	30	40	50	75	100
	PBL06		0.11	0.12	0.14	0.16	0.17	-
PBL08		0.18	0.19	0.21	0.23	0.25	-	-
PBL12		0.29	0.32	0.36	0.39	0.42	0.52	-
PBL16		0.59	0.64	0.68	0.73	0.8	0.92	-
PBL20		1.07	1.14	1.3	1.28	1.5	1.62	1.94
PBL25		1.65	1.75	1.84	1.94	2.13	2.47	2.76

※ 표준타입(전진단 Urethane Stopper 기본 장착) 중량입니다.

PBL Series

06

08

12

16

20

25

10

20

30

40

50

PBL06-10

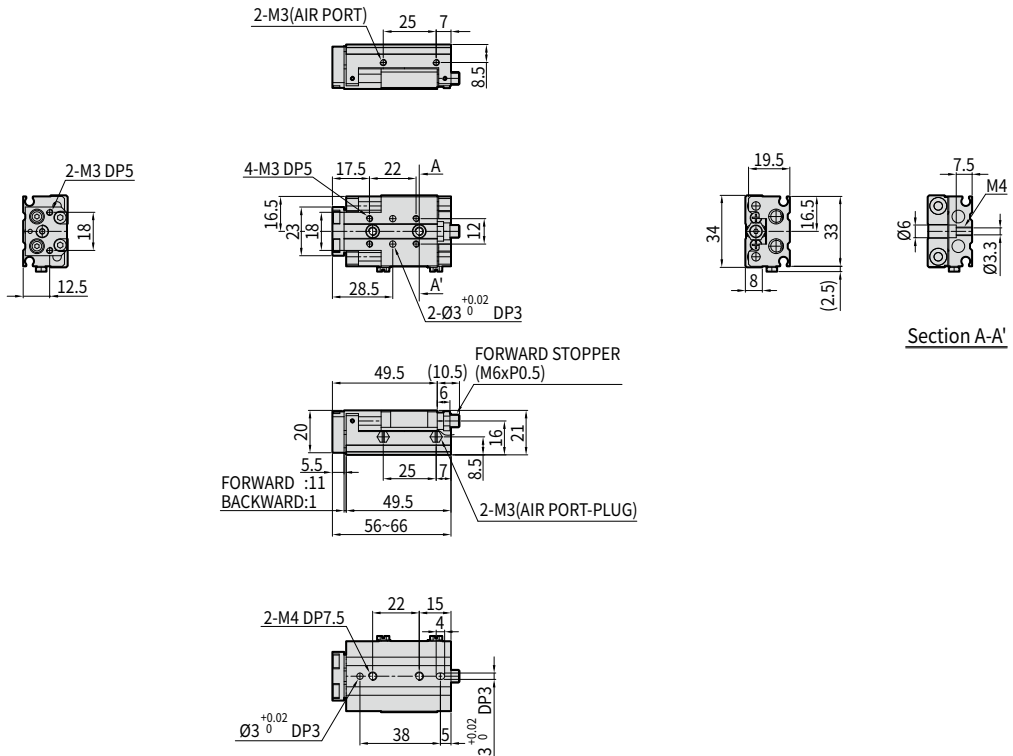

BLOCK

PT

PB

PBM-N

PQG

PBL

PBF

PGL

PGC

PBL06-10 전후진 Urethane Stopper

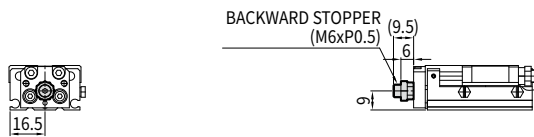

PBL06-10 Shock Absorber & Auto Switch 장착 예

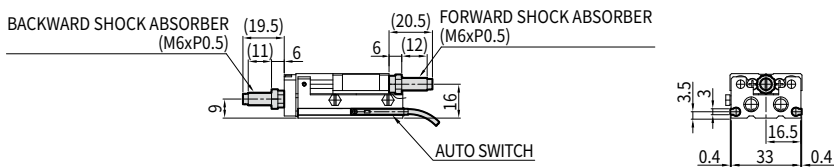

PBL Series

06

08

12

16

20

25

10

20

30

40

50

PBL06-20

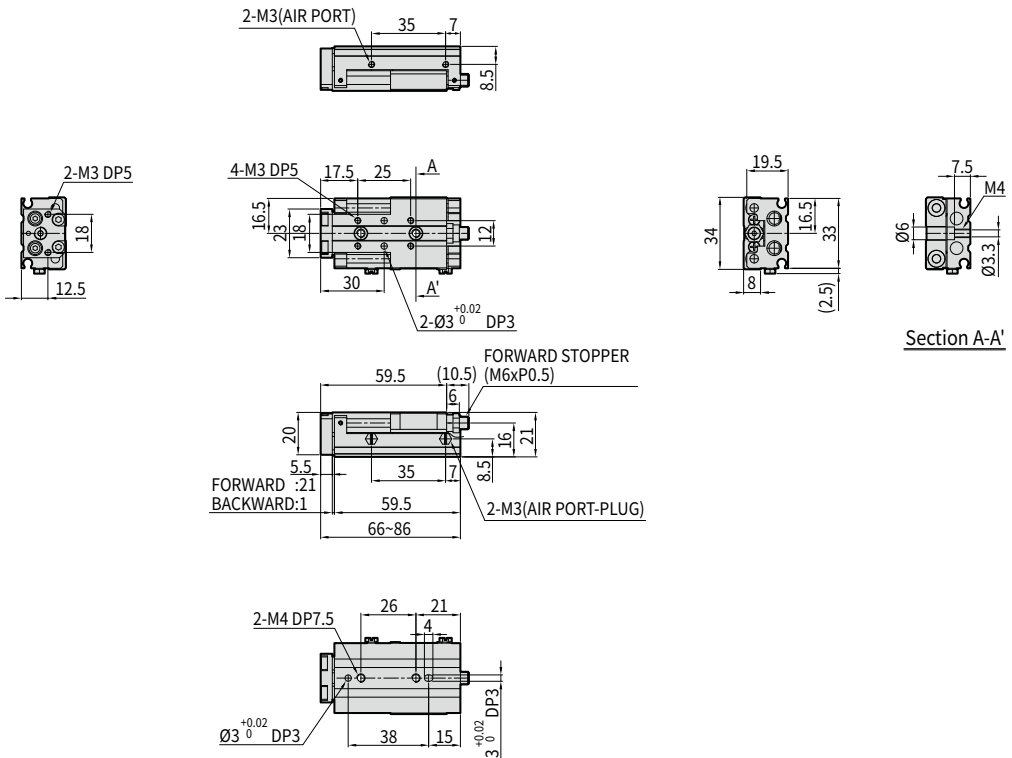

PBL06-20 전후진 Urethane Stopper

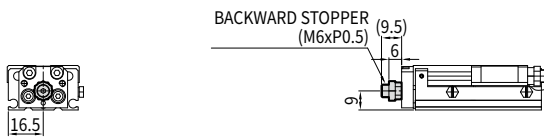

PBL06-20 Shock Absorber & Auto Switch 장착 예

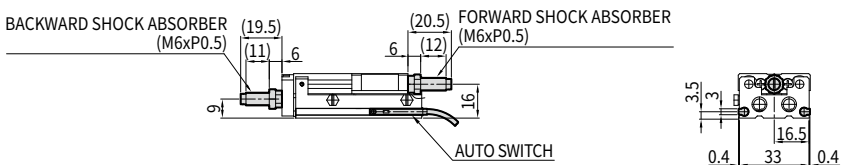

06

08

12

16

20

25

10

20

30

40

50

PBL06-30

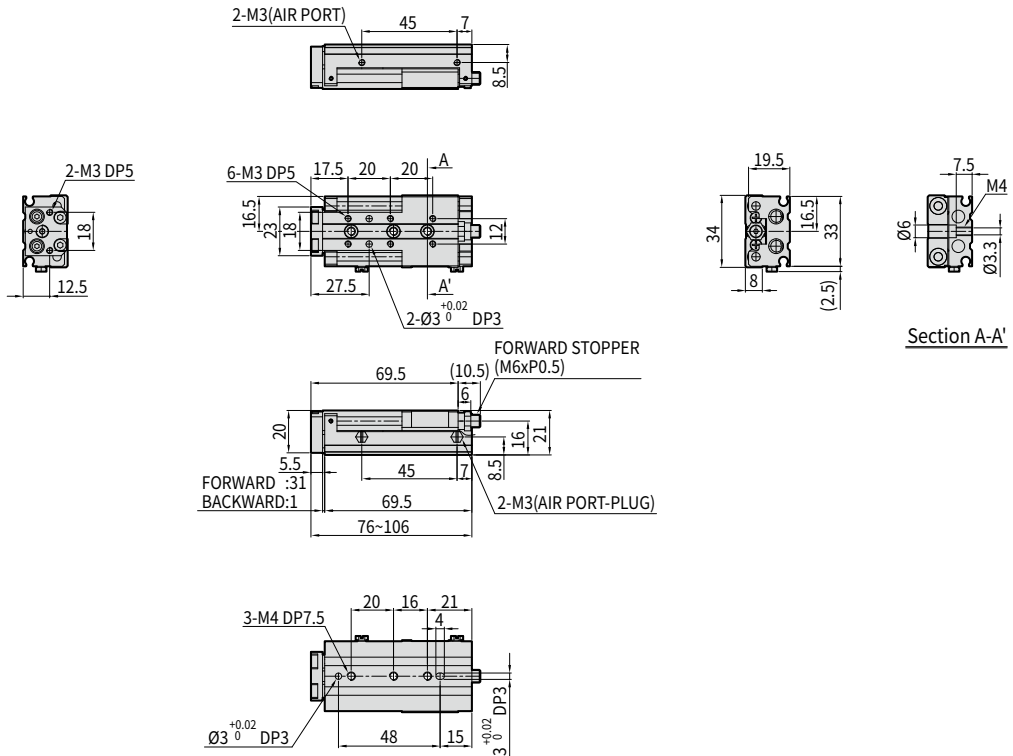

BLOCK

- PT
- PB
- PBM-N
- PQG
- PBL**
- PBF
- PGL
- PGC

PBL06-30 전후진 Urethane Stopper

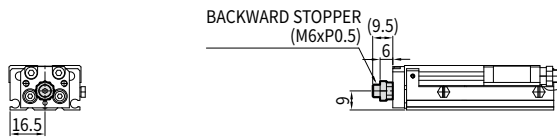

PBL06-30 Shock Absorber & Auto Switch 장착 예

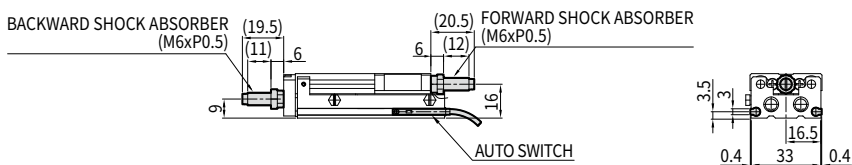

PBL Series

06

08

12

16

20

25

10

20

30

40

50

PBL06-40

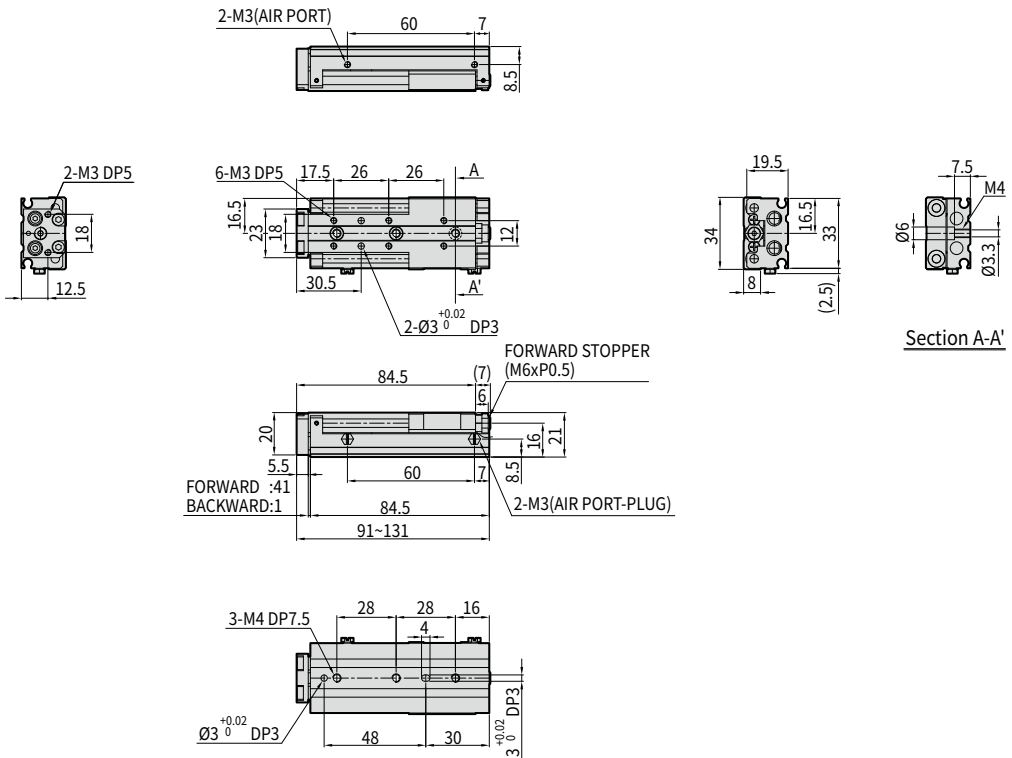

PBL06-40 전후진 Urethane Stopper

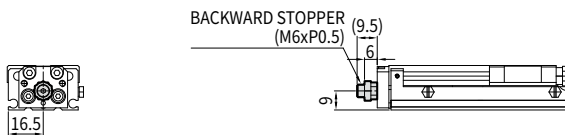

PBL06-40 Shock Absorber & Auto Switch 장착 예

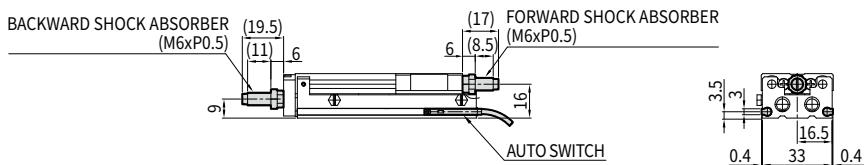

06

08

12

16

20

25

10

20

30

40

50

PBL06-50

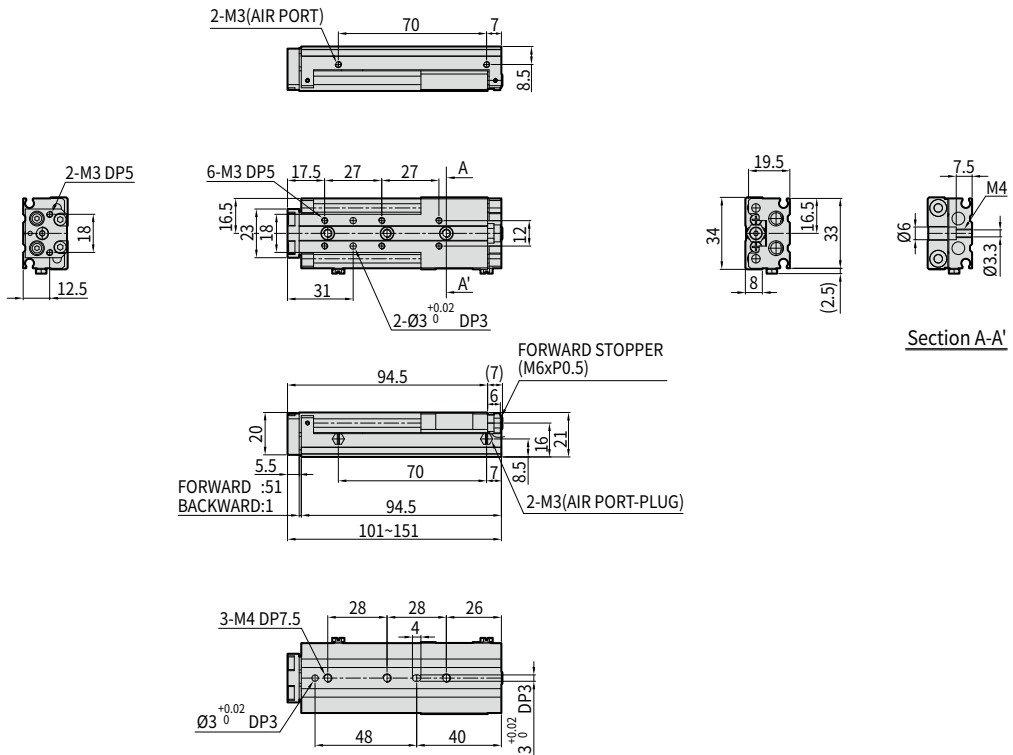

BLOCK

- PT
- PB
- PBM-N
- PQG
- PBL**
- PBF
- PGL
- PGC

PBL06-50 전후진 Urethane Stopper

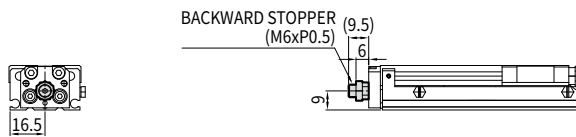

PBL06-50 Shock Absorber & Auto Switch 장착 예

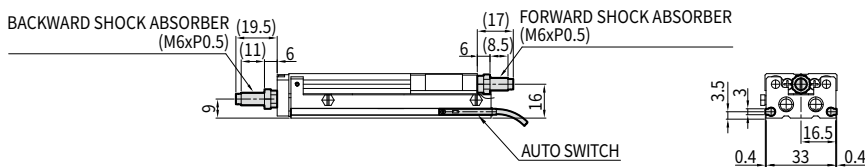

PBL Series

06

08

12

16

20

25

10

20

30

40

50

PBL08-10

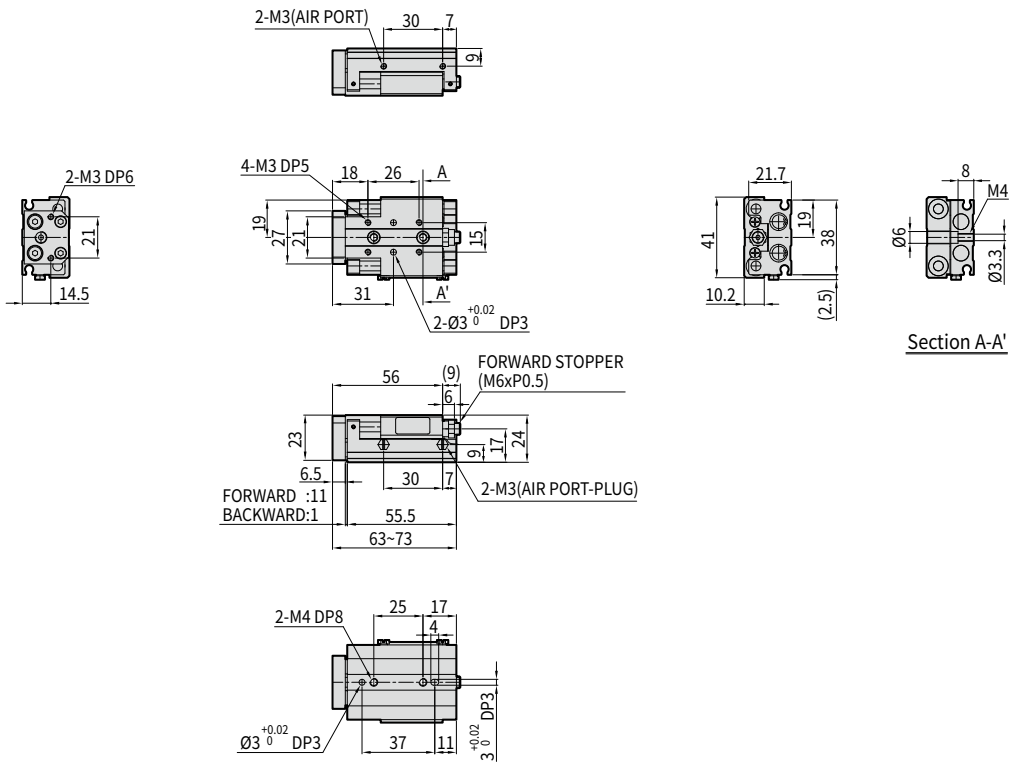

PBL08-10 전후진 Urethane Stopper

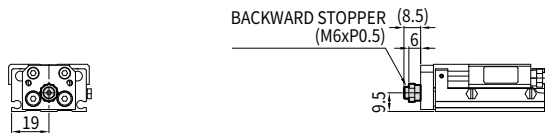

PBL08-10 Shock Absorber & Auto Switch 장착 예

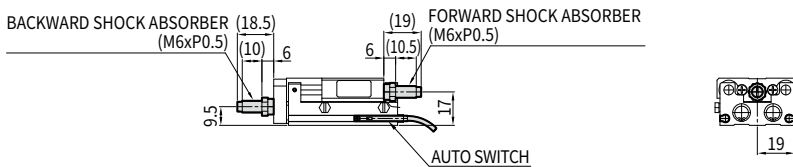

06

08

12

16

20

25

10

20

30

40

50

PBL08-20

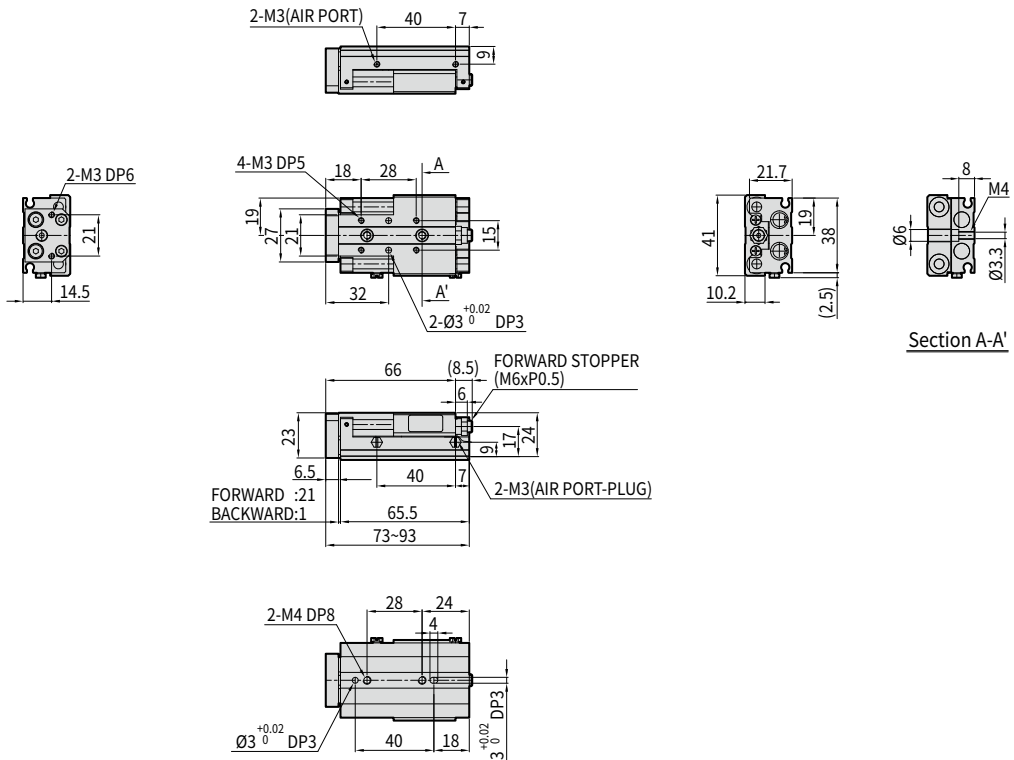

BLOCK

- PT
- PB
- PBM-N
- PQG
- PBL**
- PBF
- PGL
- PGC

PBL08-20 전후진 Urethane Stopper

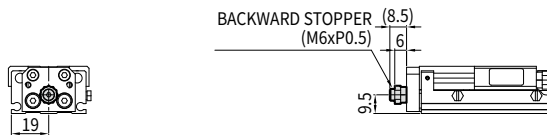

PBL08-20 Shock Absorber & Auto Switch 장착 예

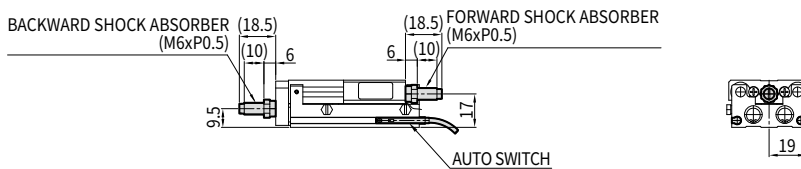

PBL Series

06

08

12

16

20

25

10

20

30

40

50

PBL08-30

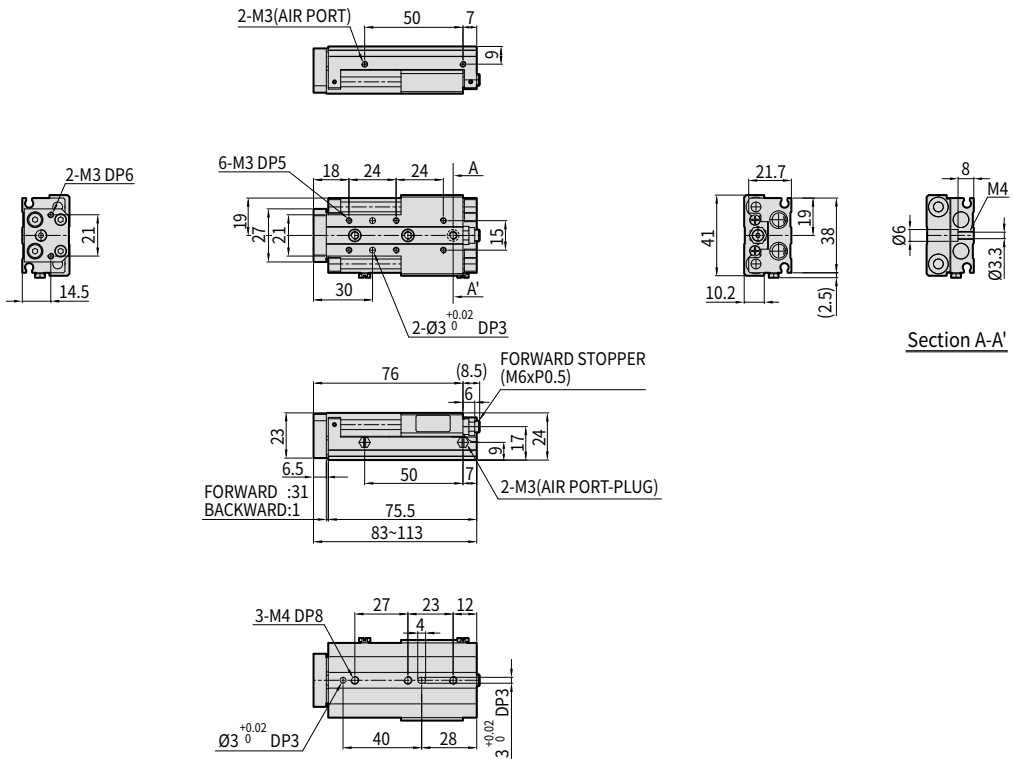

PBL08-30 전후진 Urethane Stopper

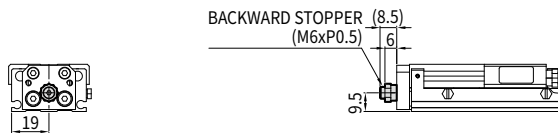

PBL08-30 Shock Absorber & Auto Switch 장착 예

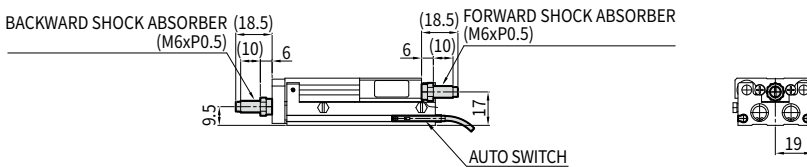

06

08

12

16

20

25

10

20

30

40

50

PBL08-40

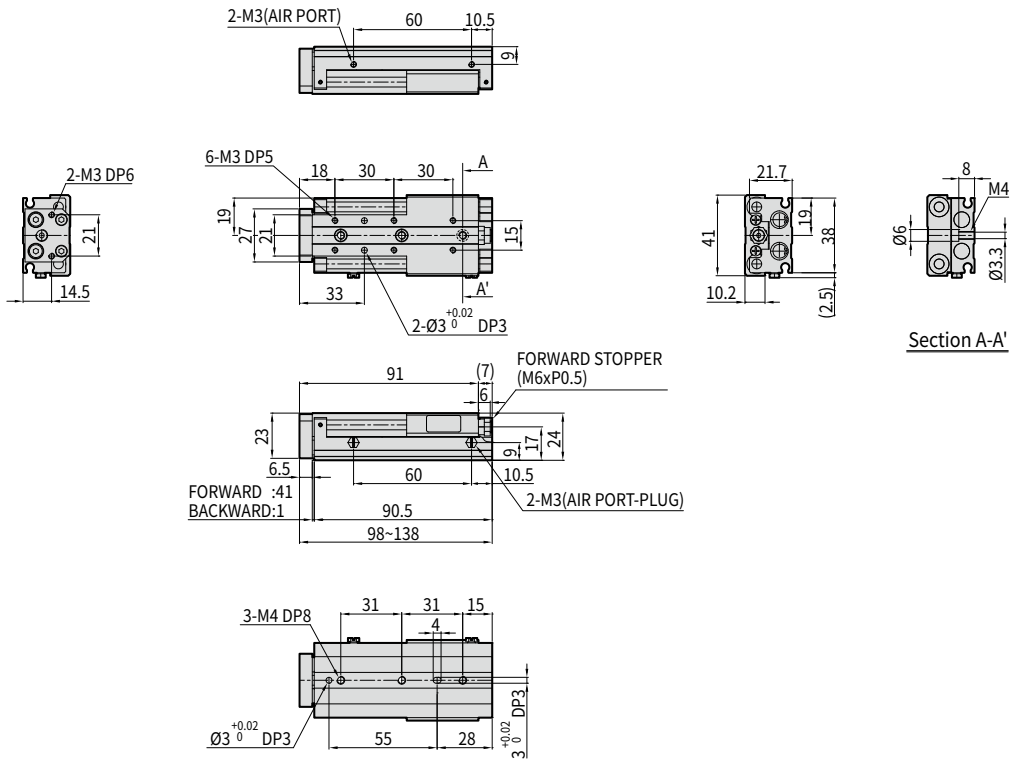

BLOCK

- PT
- PB
- PBM-N
- PQG
- PBL**
- PBF
- PGL
- PGC

PBL08-40 전후진 Urethane Stopper

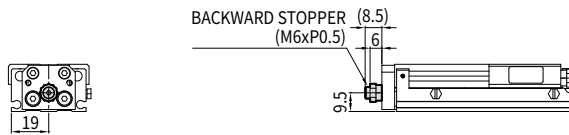

PBL08-40 Shock Absorber & Auto Switch 장착 예

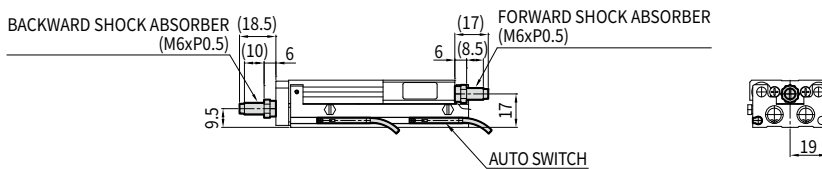

PBL Series

06

08

12

16

20

25

10

20

30

40

50

PBL08-50

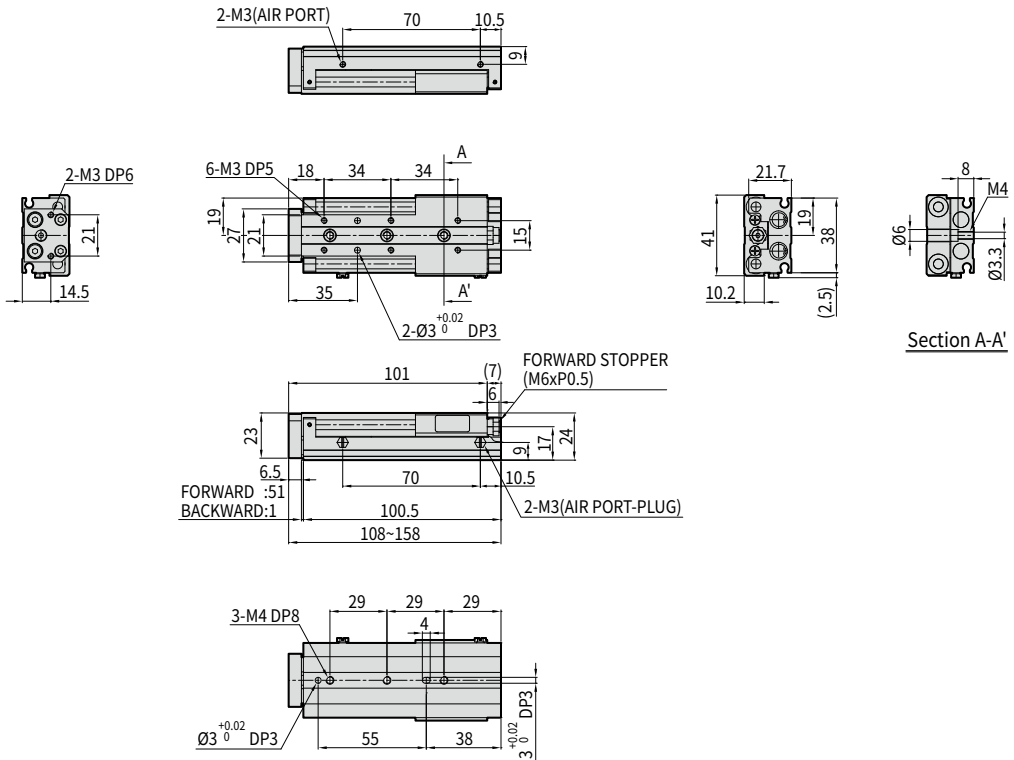

PBL08-50 전후진 Urethane Stopper

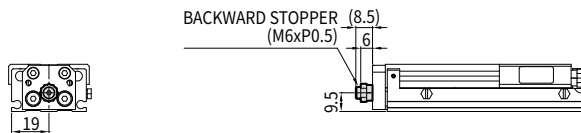

PBL08-50 Shock Absorber & Auto Switch 장착 예

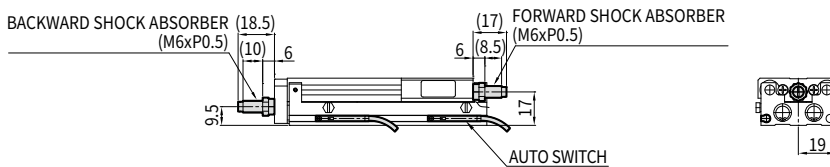

06

08

12

16

20

25

10

20

30

40

50

75

PBL12-10

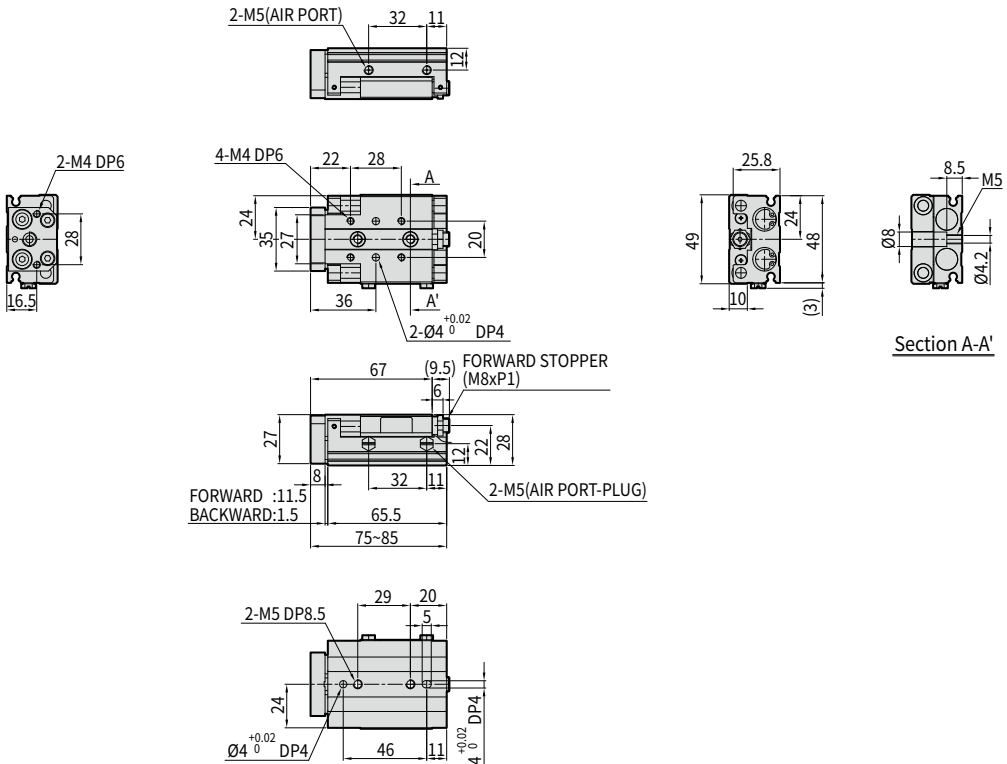

BLOCK

PT
PB
PBM-N
PQG
PBL
PBF
PGL
PGC

PBL12-10 전후진 Urethane Stopper

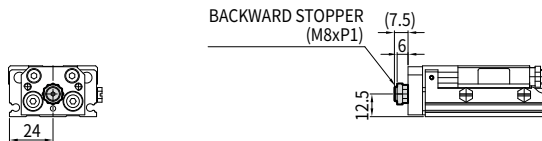

PBL12-10 Shock Absorber & Auto Switch 장착 예

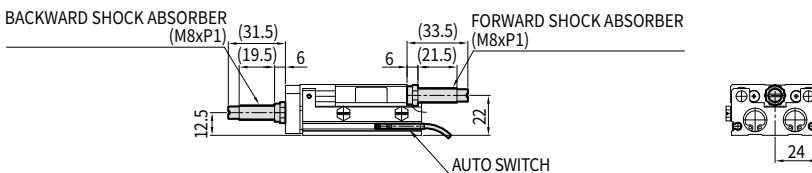

PBL Series

06

08

12

16

20

25

10

20

30

40

50

75

PBL12-20

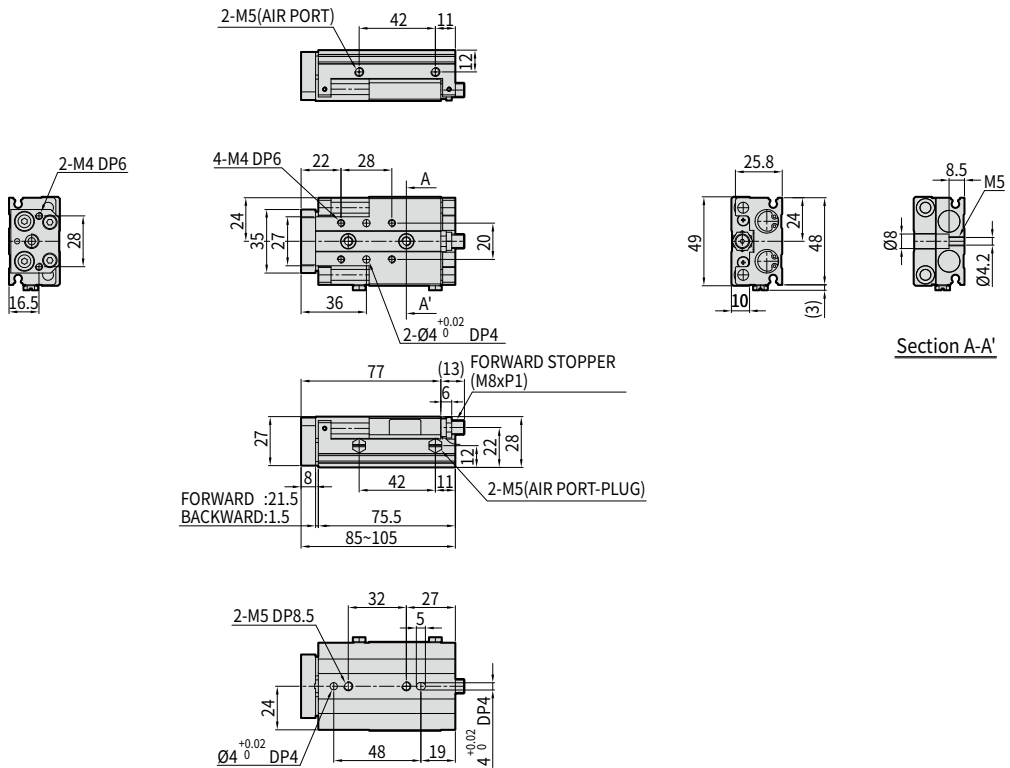

PBL12-20 전후진 Urethane Stopper

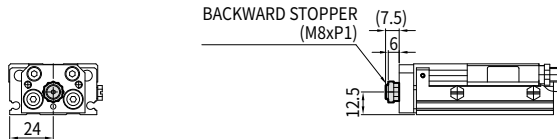

PBL12-20 Shock Absorber & Auto Switch 장착 예

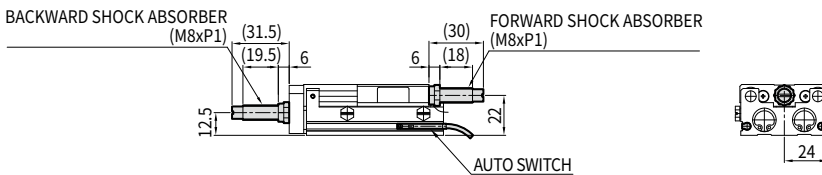

06

08

12

16

20

25

10

20

30

40

50

75

PBL12-30

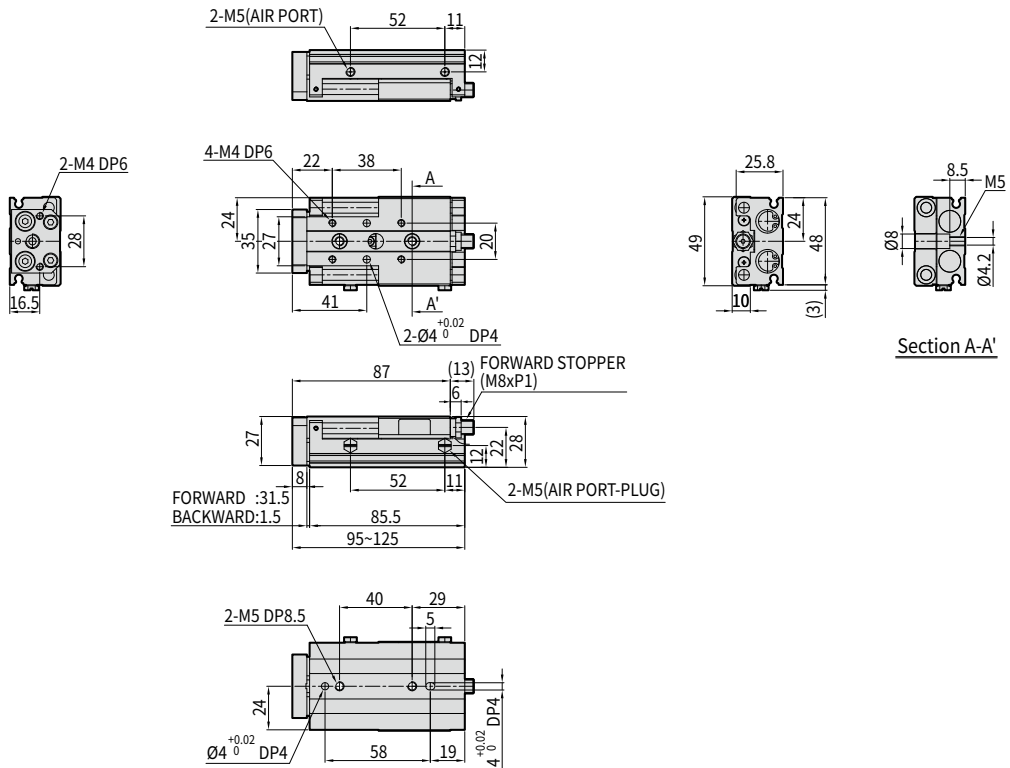

BLOCK

PT
PB
PBM-N
PQG
PBL
PBF
PGL
PGC

PBL12-30 전후진 Urethane Stopper

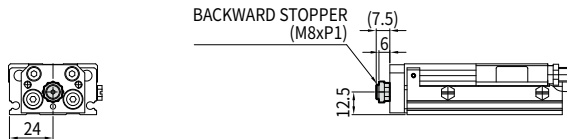

PBL12-30 Shock Absorber & Auto Switch 장착 예

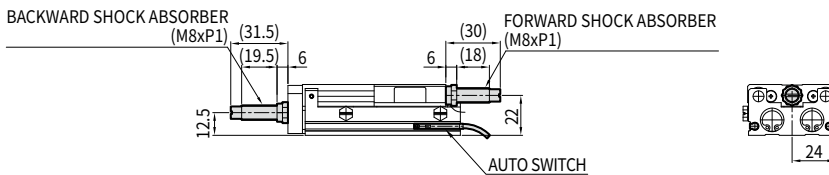

PBL Series

06

08

12

16

20

25

10

20

30

40

50

75

PBL12-40

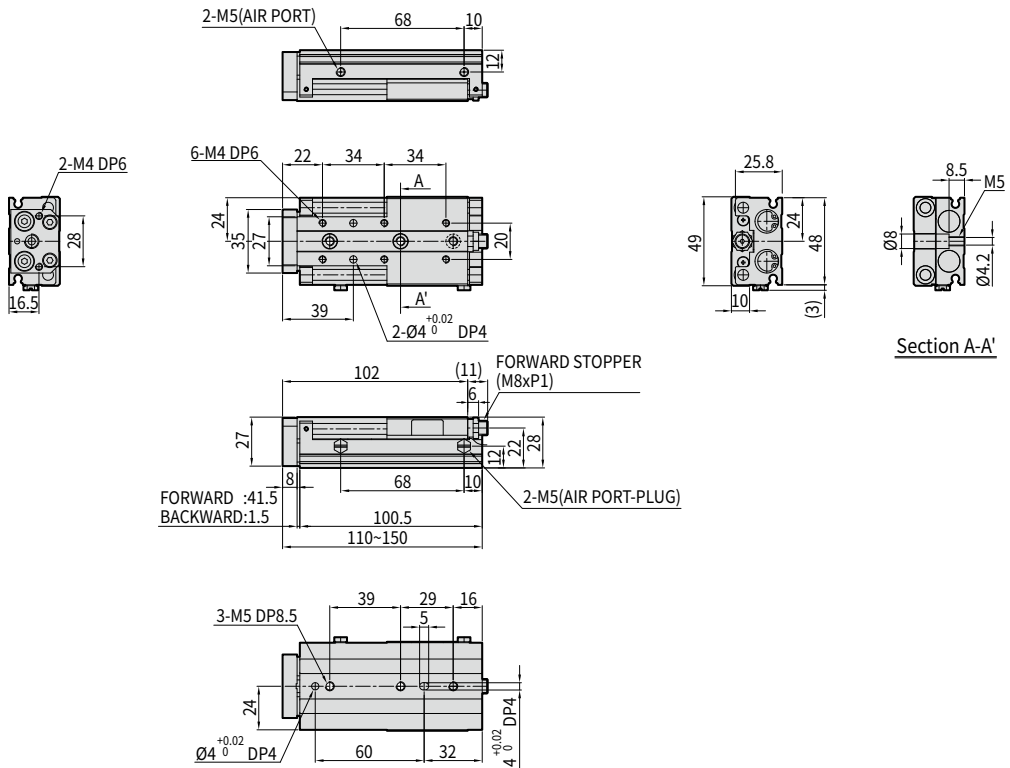

PBL12-40 전후진 Urethane Stopper

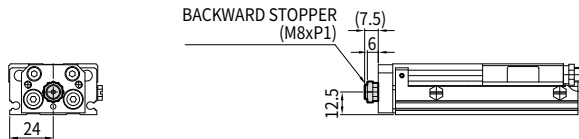

PBL12-40 Shock Absorber & Auto Switch 장착 예

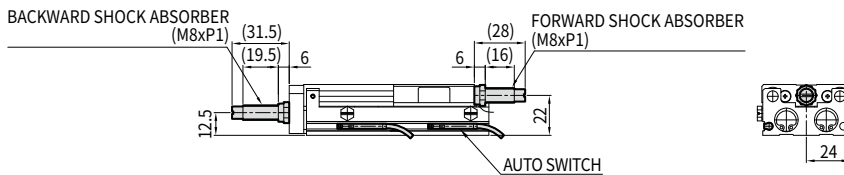

06 08 12 16 20 25

10 20 30 40 50 75

PBL12-50

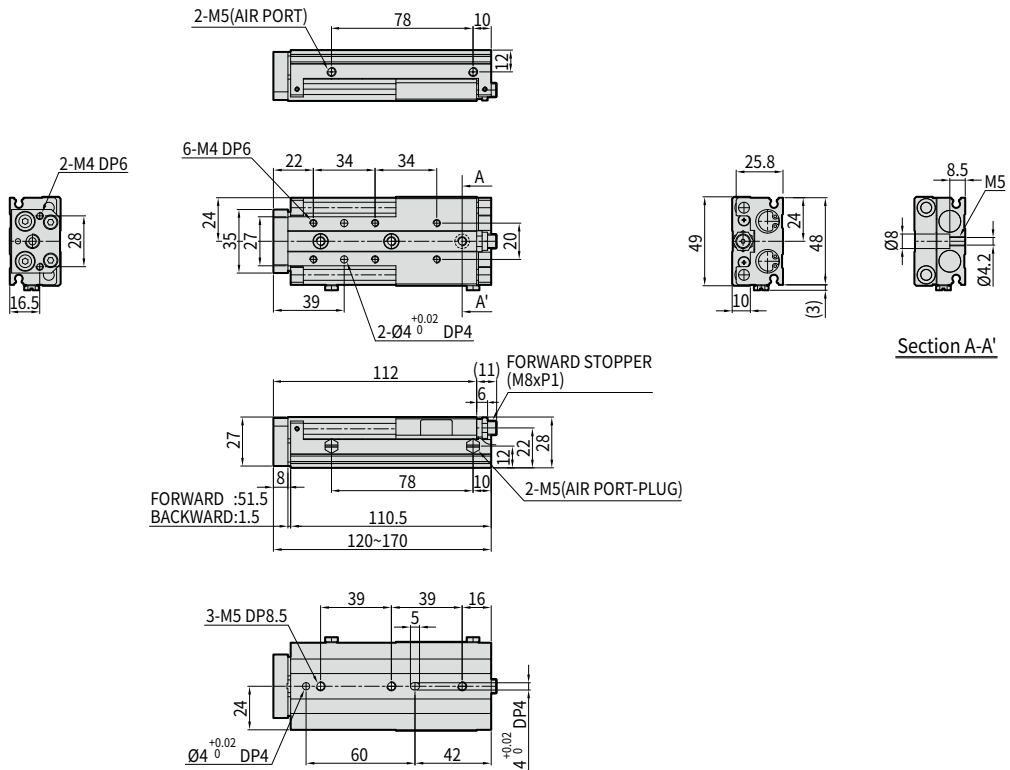

BLOCK

PT
PB
PBM-N
PQG
PBL
PBF
PGL
PGC

PBL12-50 전후진 Urethane Stopper

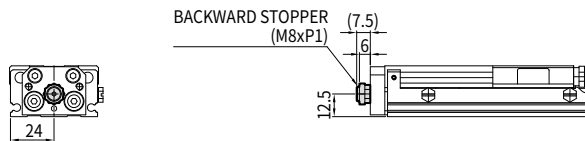

PBL12-50 Shock Absorber & Auto Switch 장착 예

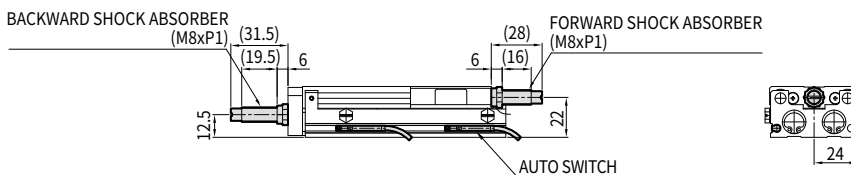

PBL Series

06	08	12	16	20	25
10	20	30	40	50	75

PBL12-75

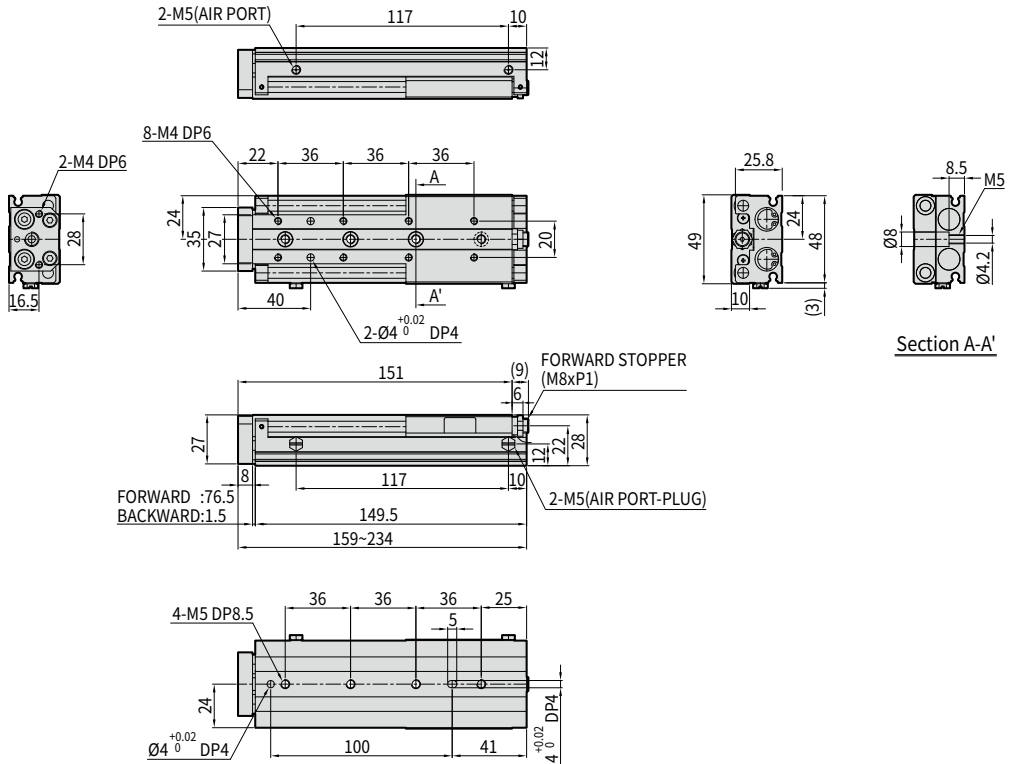

PBL12-75 전후진 Urethane Stopper

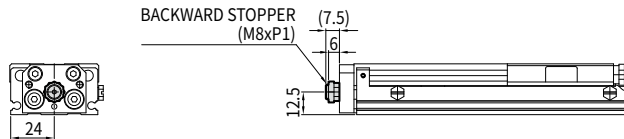

PBL12-75 Shock Absorber & Auto Switch 장착 예

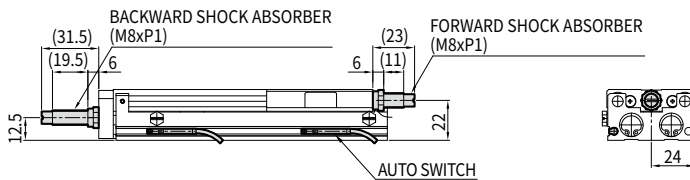

06

08

12

16

20

25

10

20

30

40

50

75

PBL16-10

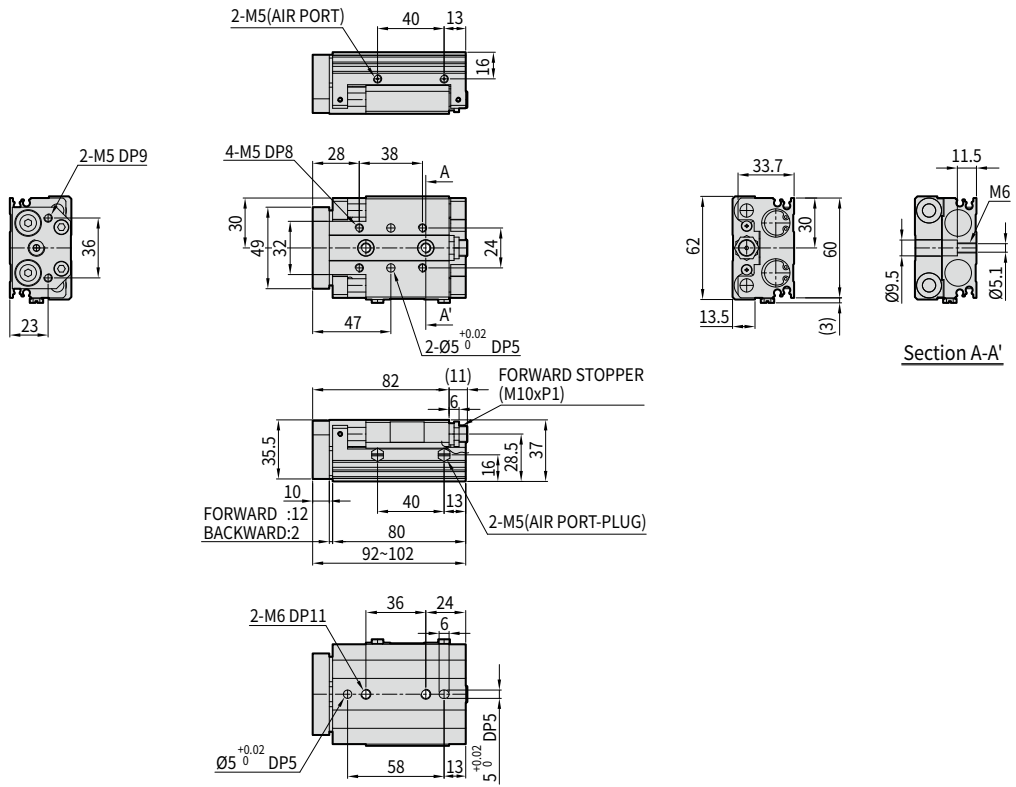

BLOCK

PT

PB

PBM-N

PQG

PBL

PBF

PGL

PGC

PBL16-10 전후진 Urethane Stopper

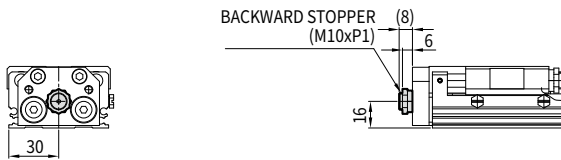

PBL16-10 Shock Absorber & Auto Switch 장착 예

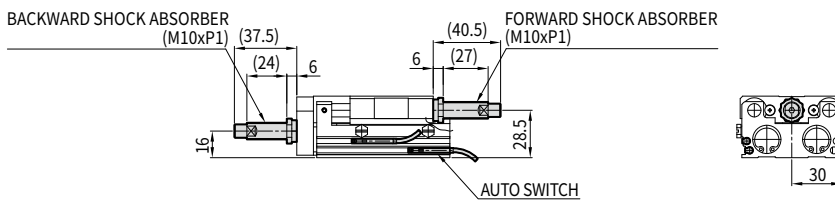

PBL Series

06	08	12	16	20	25
10	20	30	40	50	75

PBL16-20

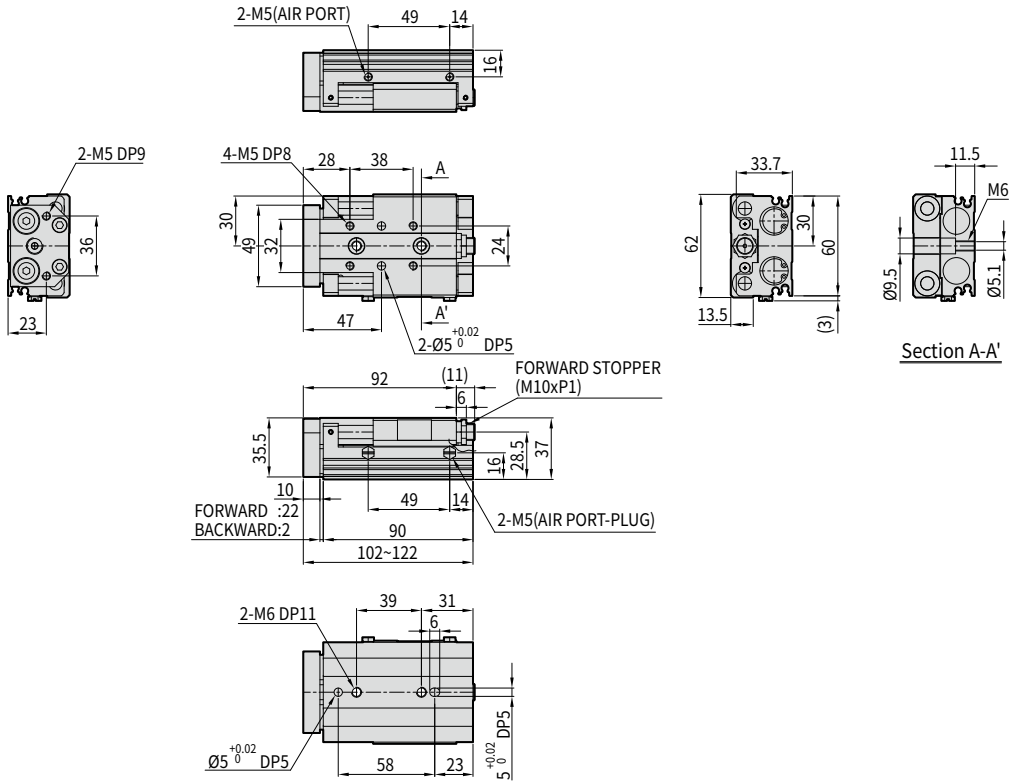

PBL16-20 전후진 Urethane Stopper

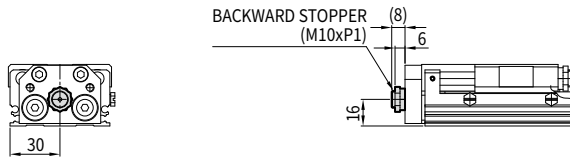

PBL16-20 Shock Absorber & Auto Switch 장착 예

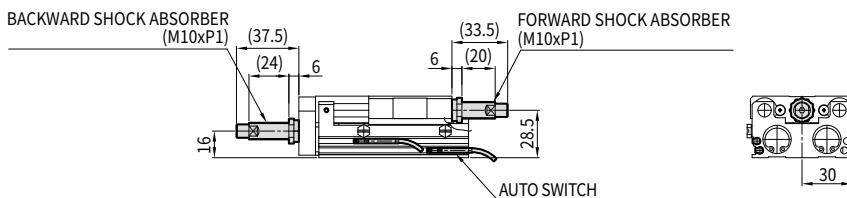

06

08

12

16

20

25

10

20

30

40

50

75

PBL16-30

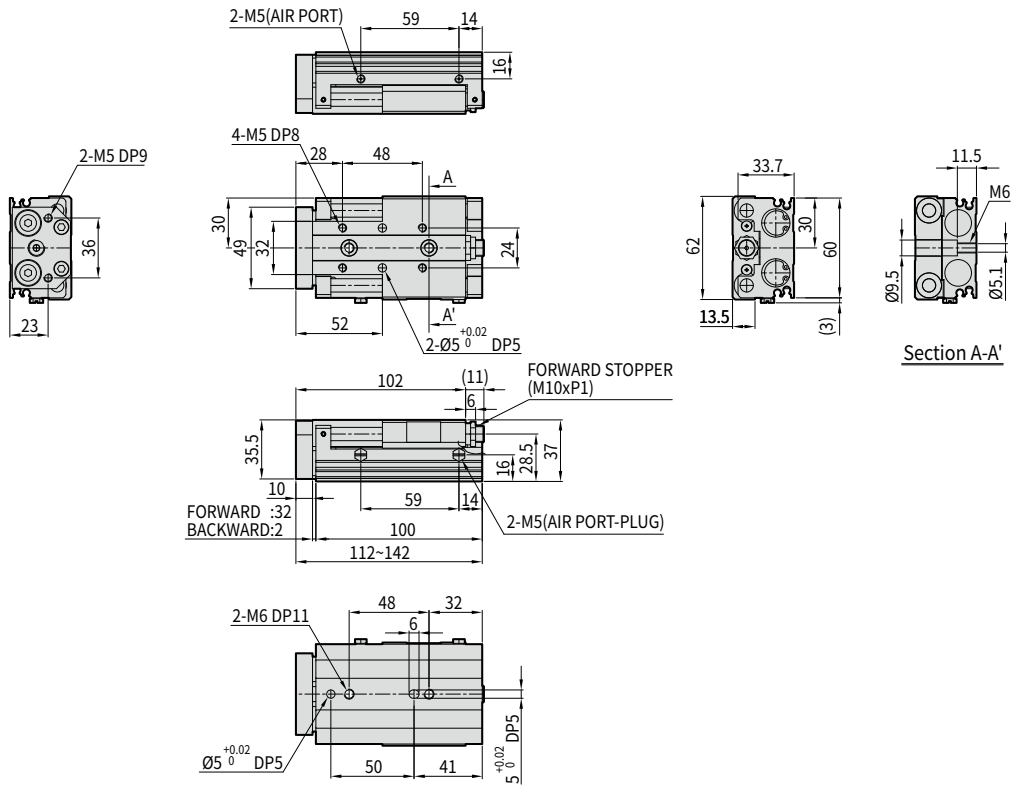

BLOCK

PT

PB

PBM-N

PQG

PBL

PBF

PGL

PGC

PBL16-30 전후진 Urethane Stopper

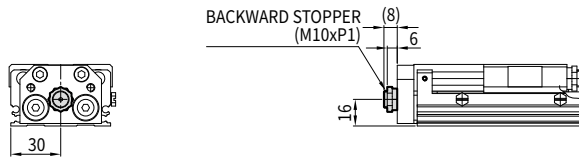

PBL16-30 Shock Absorber & Auto Switch 장착 예

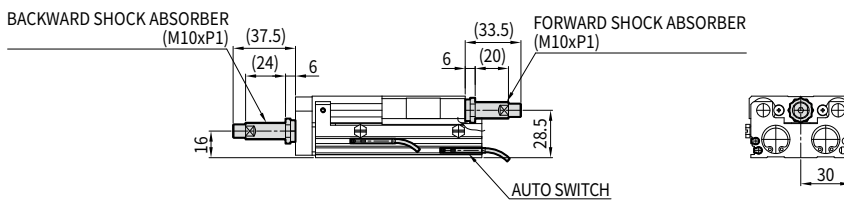

PBL Series

06	08	12	16	20	25
10	20	30	40	50	75

PBL16-40

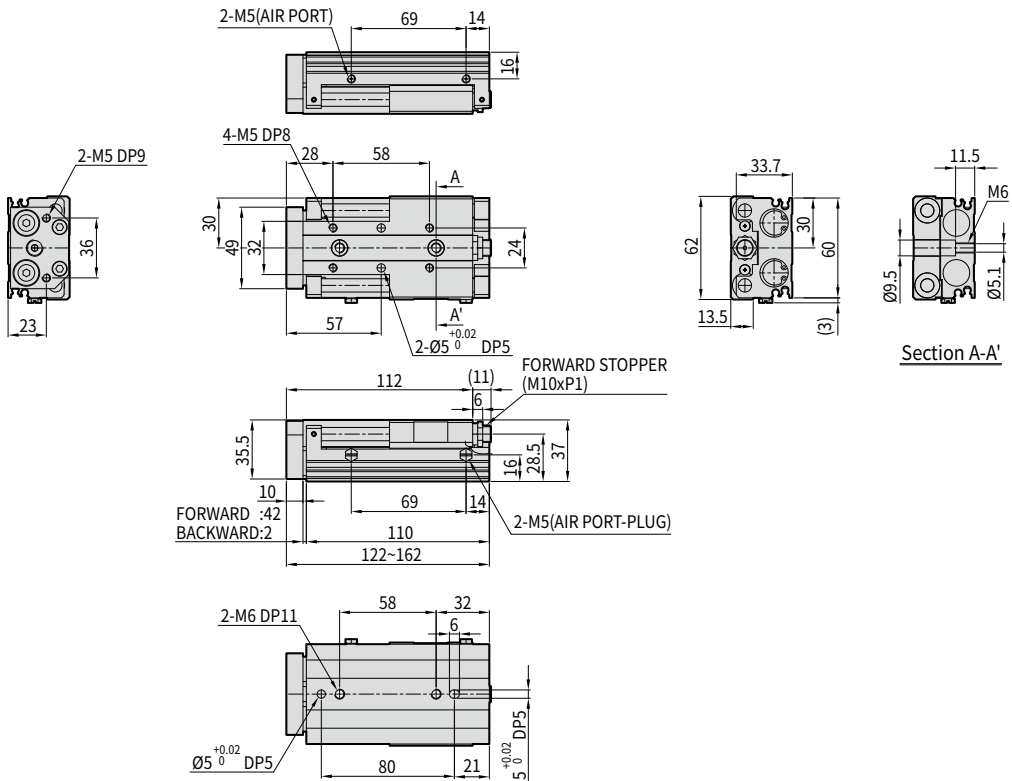

PBL16-40 전후진 Urethane Stopper

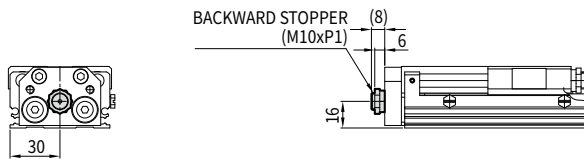

PBL16-40 Shock Absorber & Auto Switch 장착 예

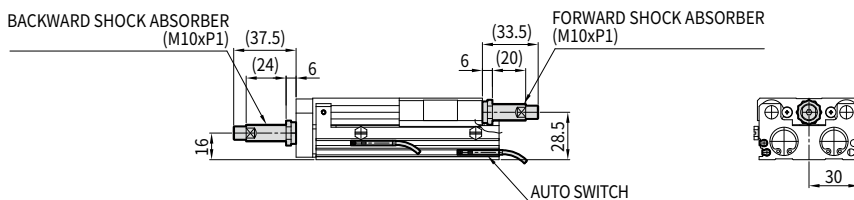

- 06
- 08
- 12
- 16
- 20
- 25
- 10
- 20
- 30
- 40
- 50
- 75

PBL16-50

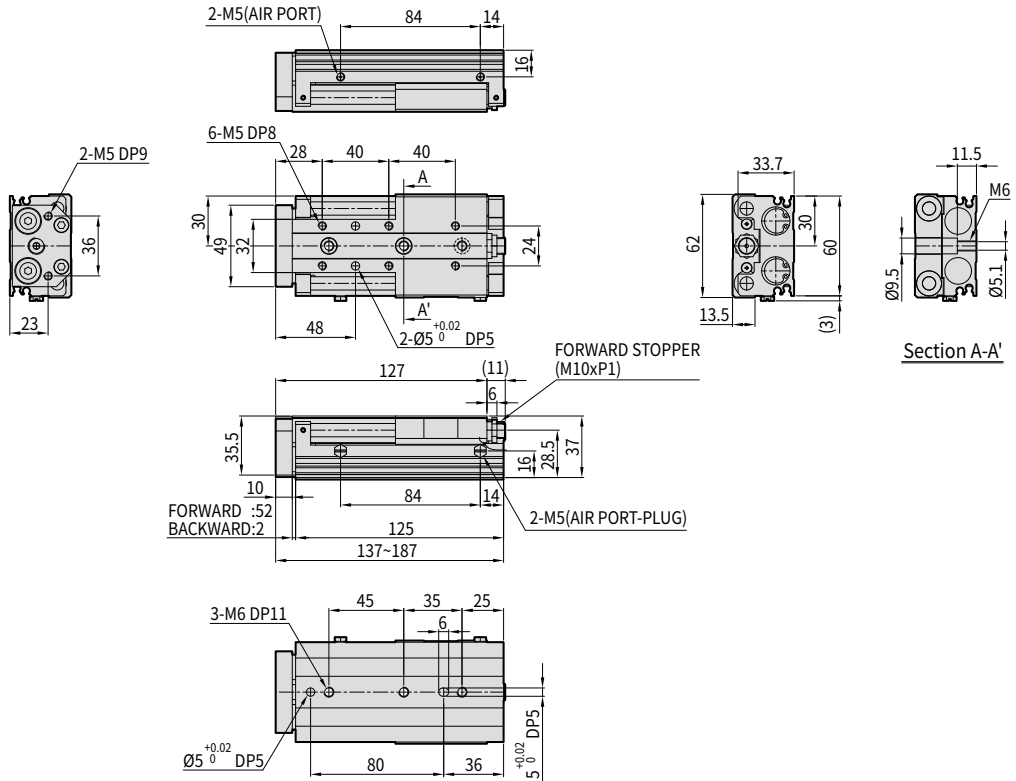

BLOCK

PT
PB
PBM-N
PQG
PBL
PBF
PGL
PGC

PBL16-50 전후진 Urethane Stopper

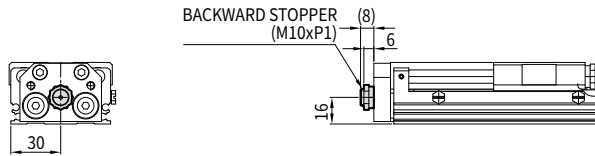

PBL16-50 Shock Absorber & Auto Switch 장착 예

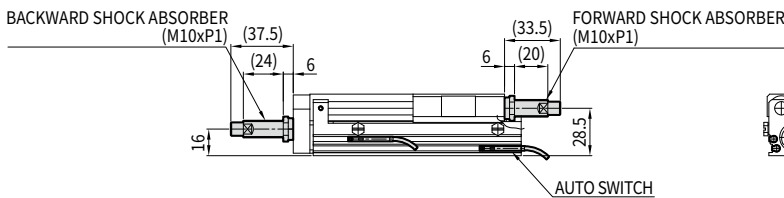

PBL Series

06

08

12

16

20

25

10

20

30

40

50

75

PBL16-75

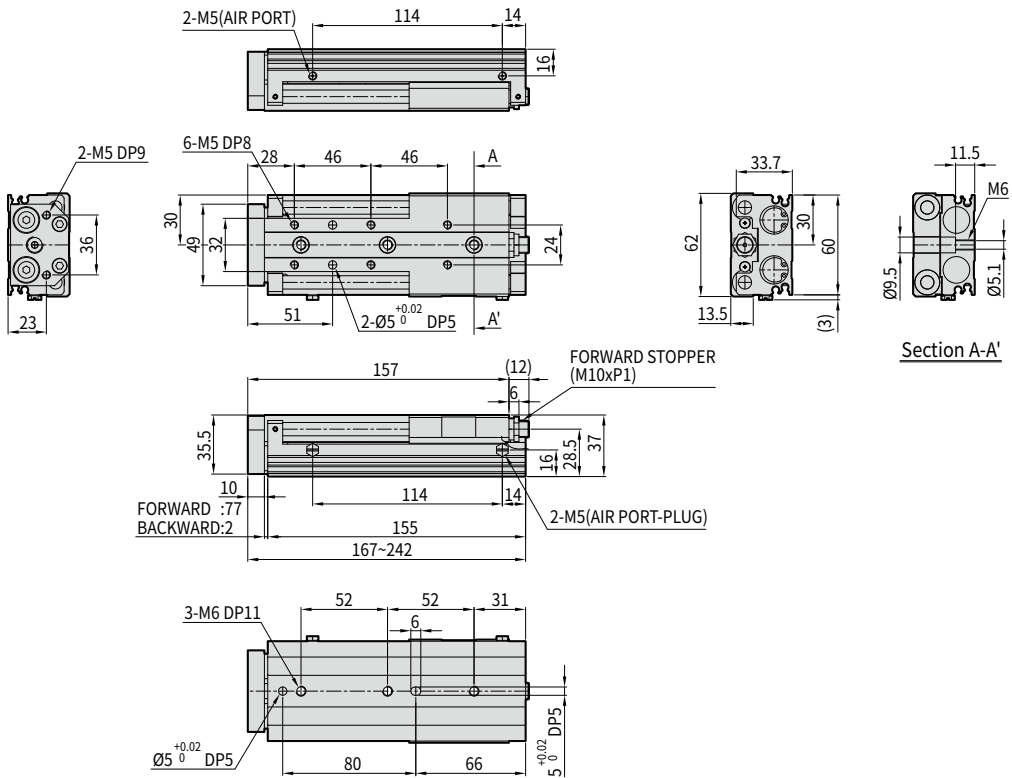

PBL16-75 전후진 Urethane Stopper

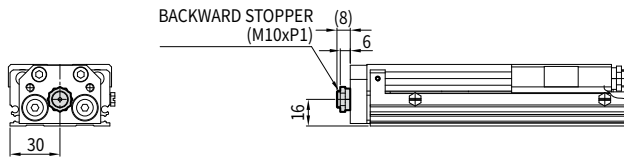

PBL16-75 Shock Absorber & Auto Switch 장착 예

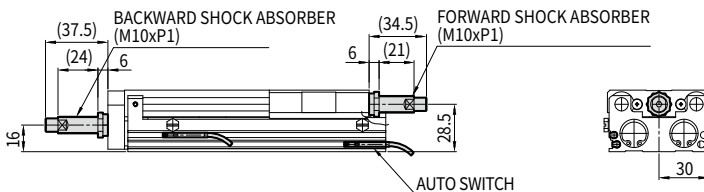

06

08

12

16

20

25

10

20

30

40

50

75

100

PBL20-10

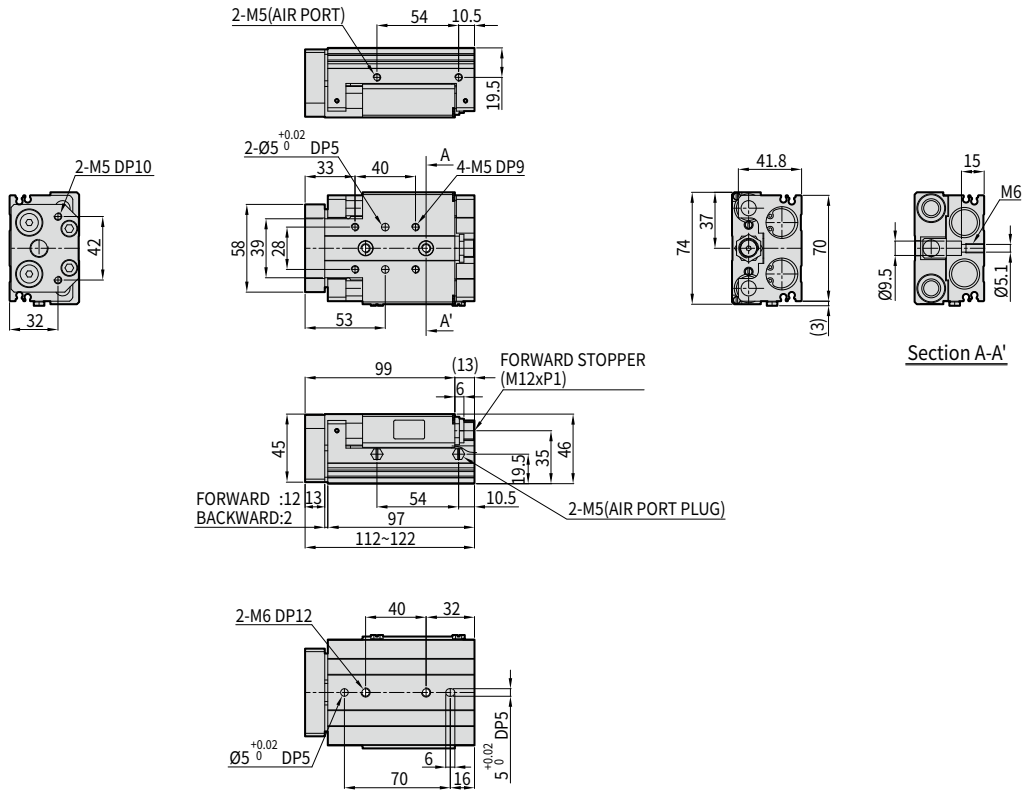

BLOCK

PT

PB

PBM-N

PQG

PBL

PBF

PGL

PGC

PBL20-10 전후진 Urethane Stopper

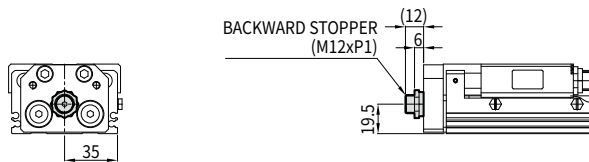

PBL20-10 Shock Absorber & Auto Switch 장착 예

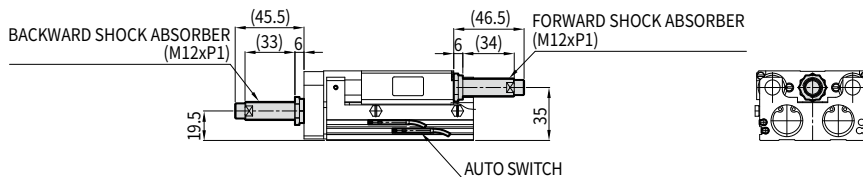

PBL Series

	06	08	12	16	20	25
10	20	30	40	50	75	100

PBL20-20

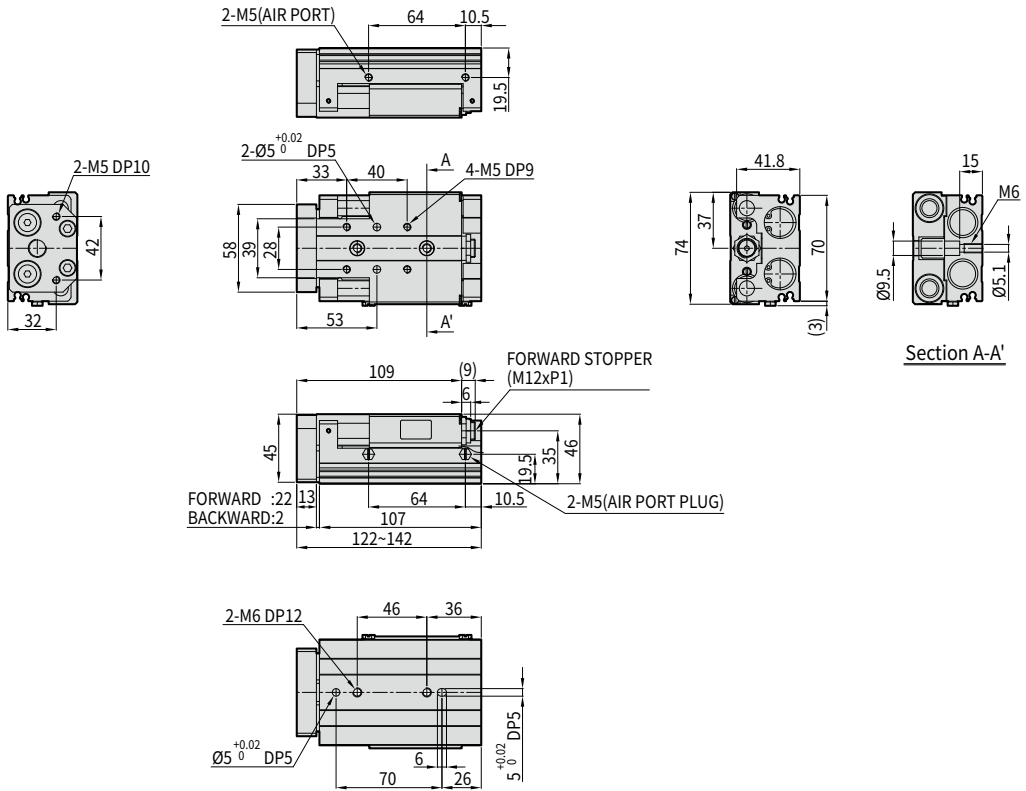

PBL20-20 전후진 Urethane Stopper

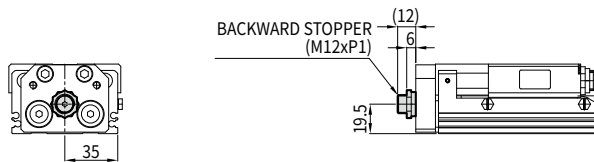

PBL20-20 Shock Absorber & Auto Switch 장착 예

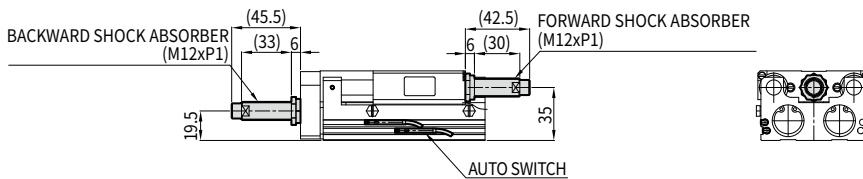

- 06
- 08
- 12
- 16
- 20
- 25
- 10
- 20
- 30
- 40
- 50
- 75
- 100

PBL20-30

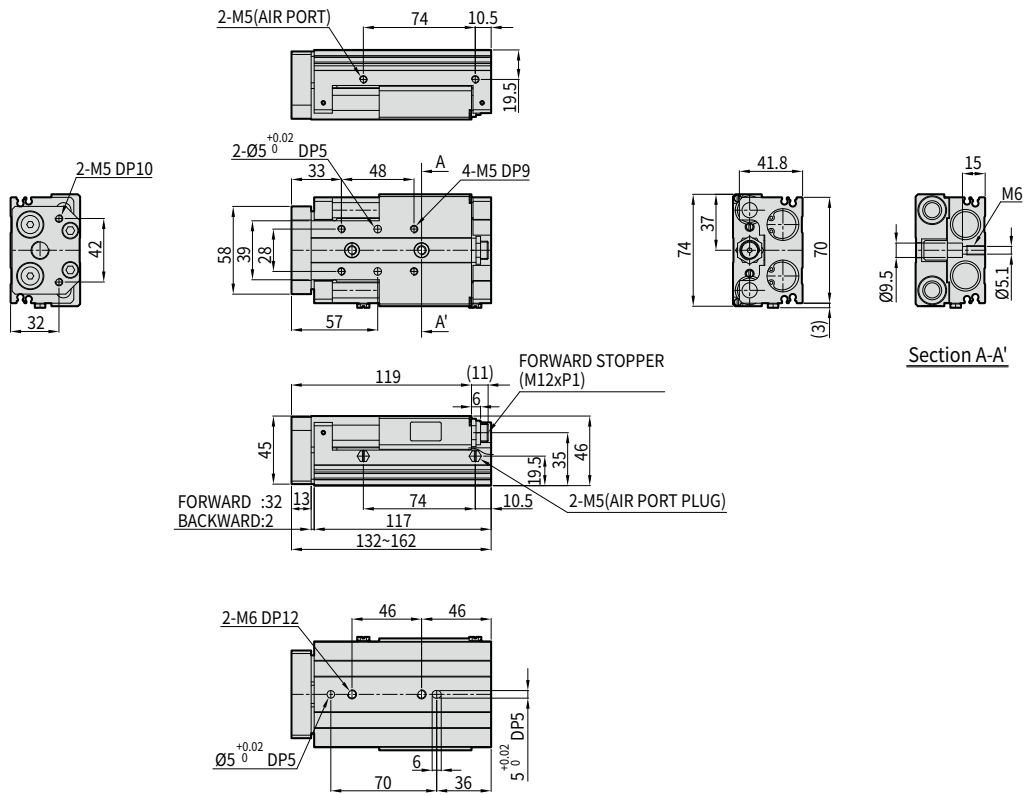

BLOCK

PT
PB
PBM-N
PQG
PBL
PBF
PGL
PGC

PBL20-30 전후진 Urethane Stopper

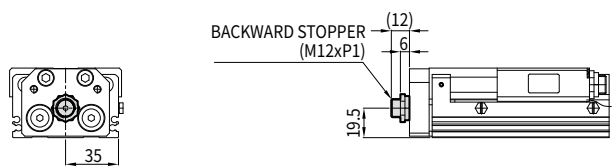

PBL20-30 Shock Absorber & Auto Switch 장착 예

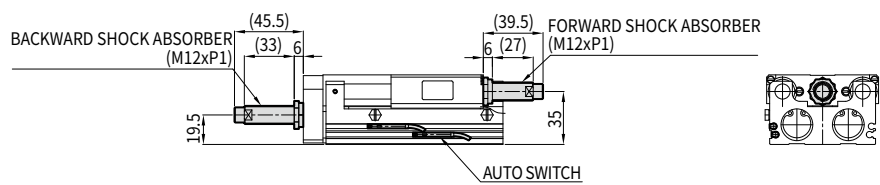

PBL Series

	06	08	12	16	20	25
10	20	30	40	50	75	100

PBL20-40

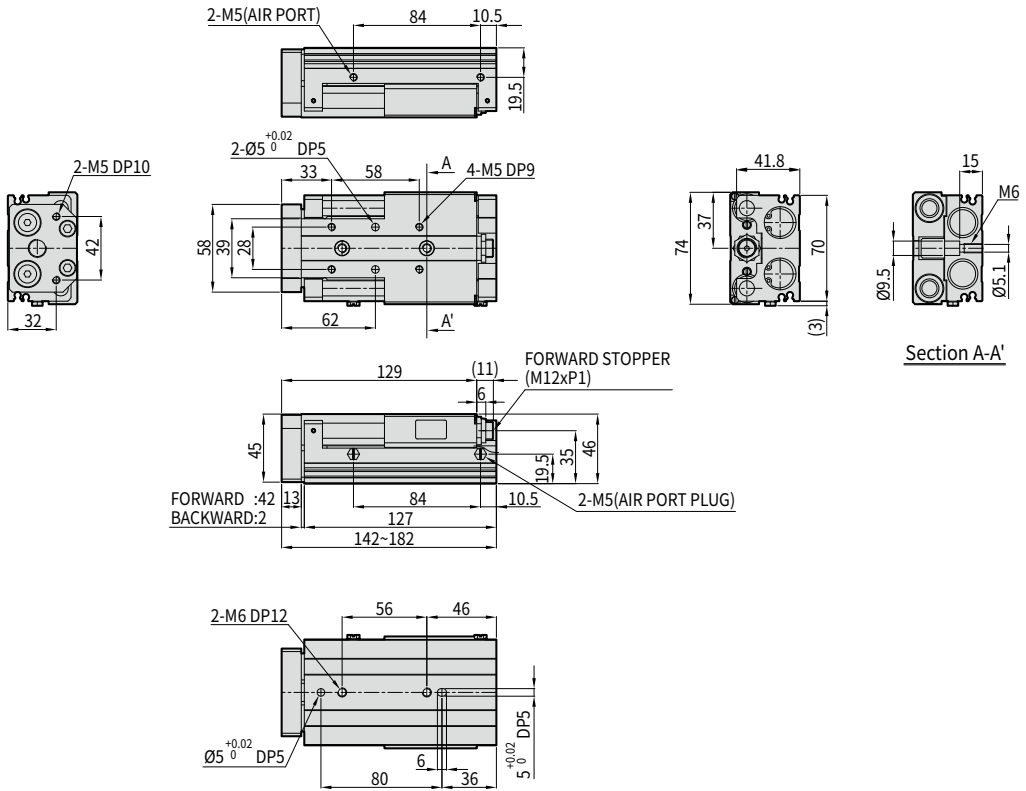

PBL20-40 전후진 Urethane Stopper

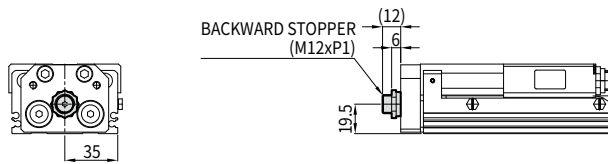

PBL20-40 Shock Absorber & Auto Switch 장착 예

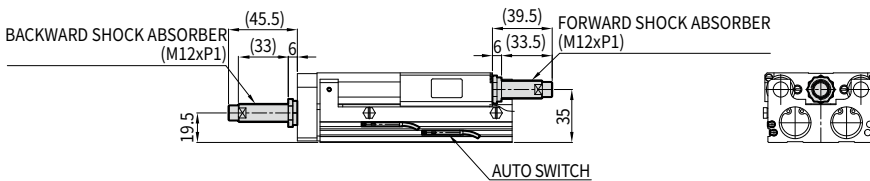

06	08	12	16	20	25
10	20	30	40	50	100

PBL20-50

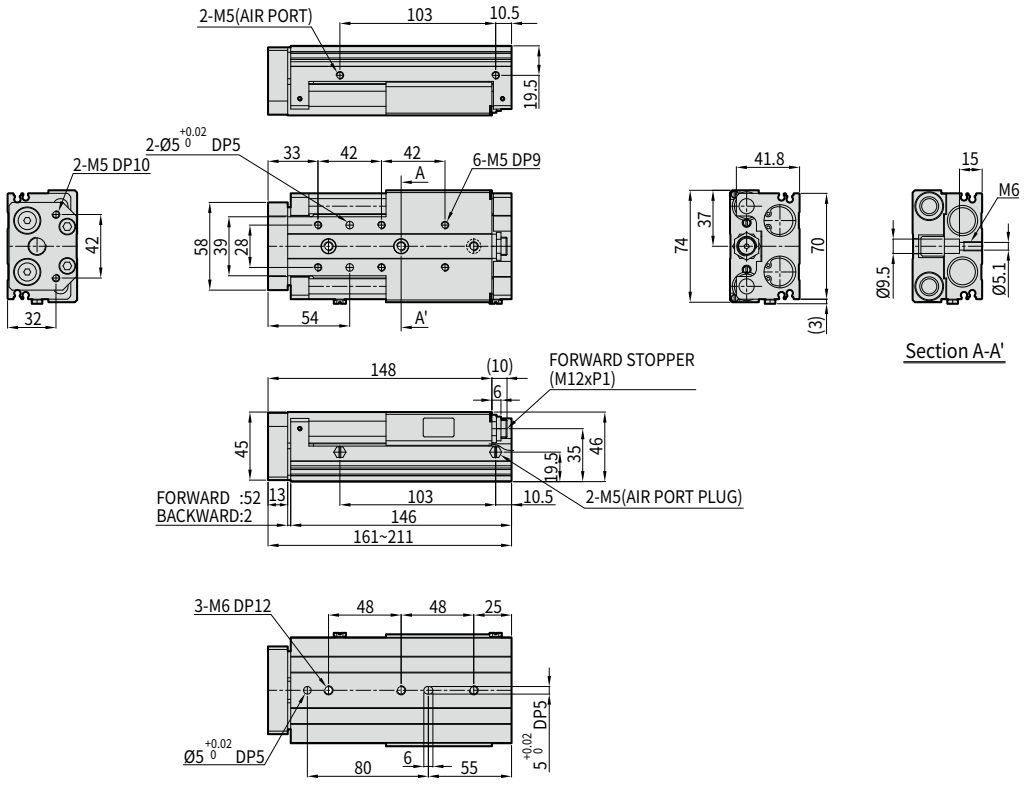

BLOCK

PT
PB
PBM-N
PQG
PBL
PBF
PGL
PGC

PBL20-50 전후진 Urethane Stopper

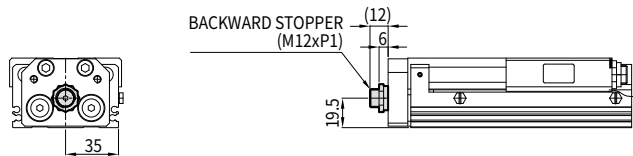

PBL20-50 Shock Absorber & Auto Switch 장착 예

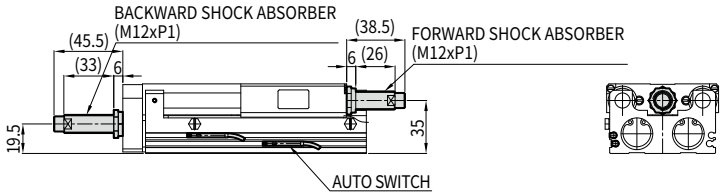

PBL Series

	06	08	12	16	20	25
10	20	30	40	50	75	100

PBL20-75

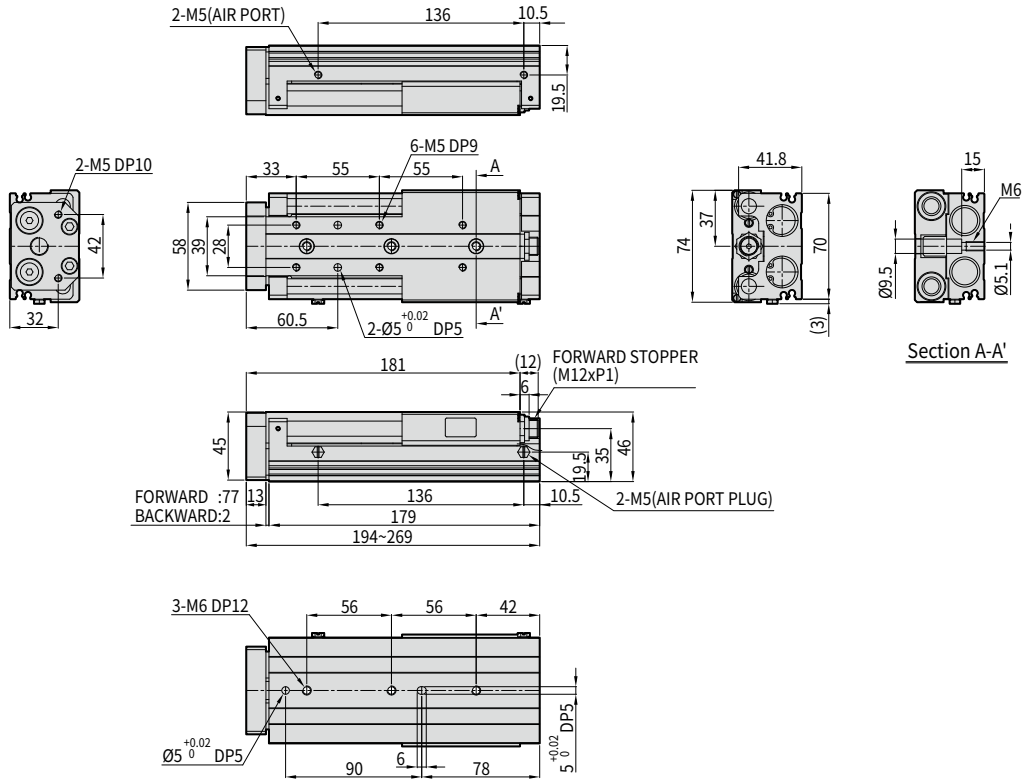

PBL20-75 전후진 Urethane Stopper

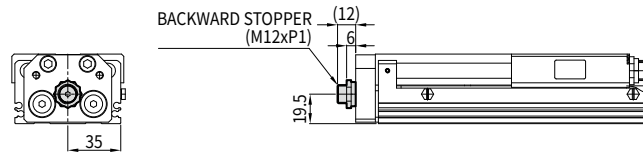

PBL20-75 Shock Absorber & Auto Switch 장착 예

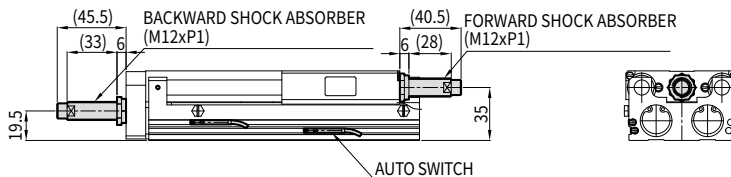

- 06
- 08
- 12
- 16
- 20
- 25
- 10
- 20
- 30
- 40
- 50
- 75
- 100

PBL20-100

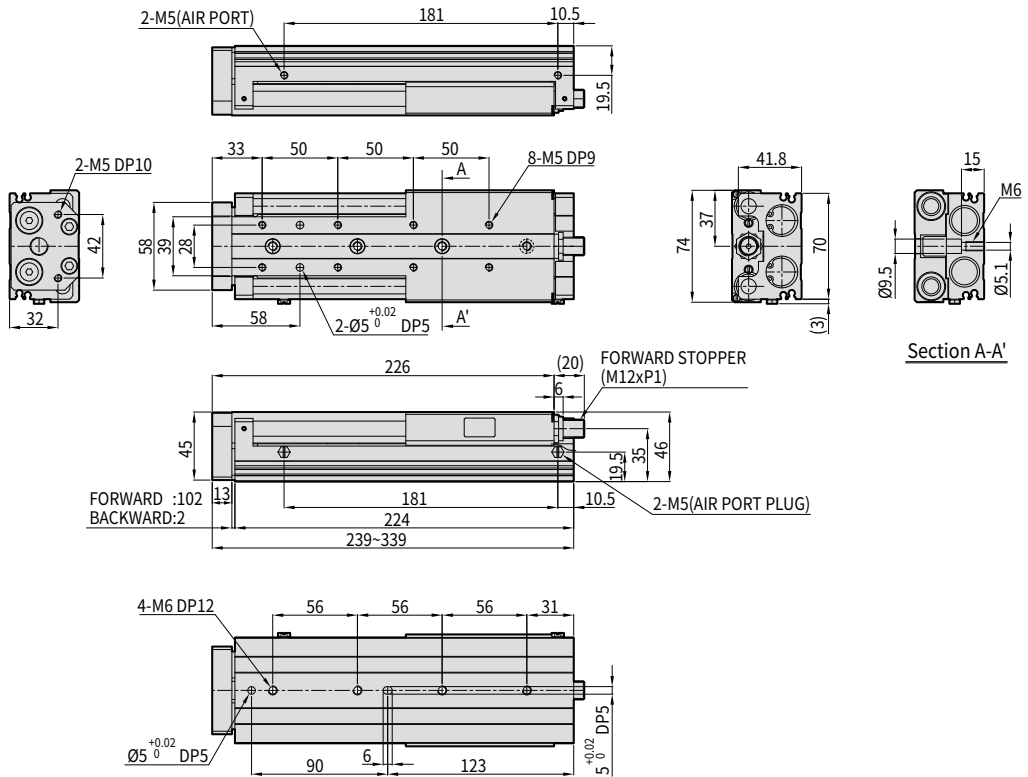

- BLOCK**
- PT
 - PB
 - PBM-N
 - PQG
 - PBL
 - PBF
 - PGL
 - PGC

PBL20-100 전후진 Urethane Stopper

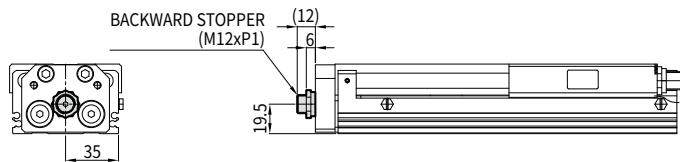

PBL20-100 Shock Absorber & Auto Switch 장착 예

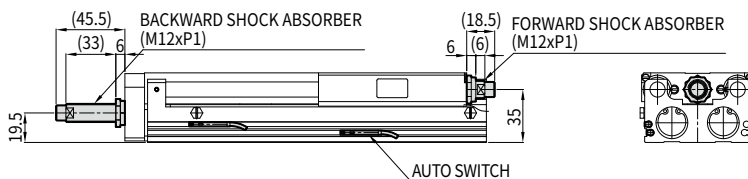

PBL Series

	06	08	12	16	20	25
10	20	30	40	50	75	100

PBL25-10

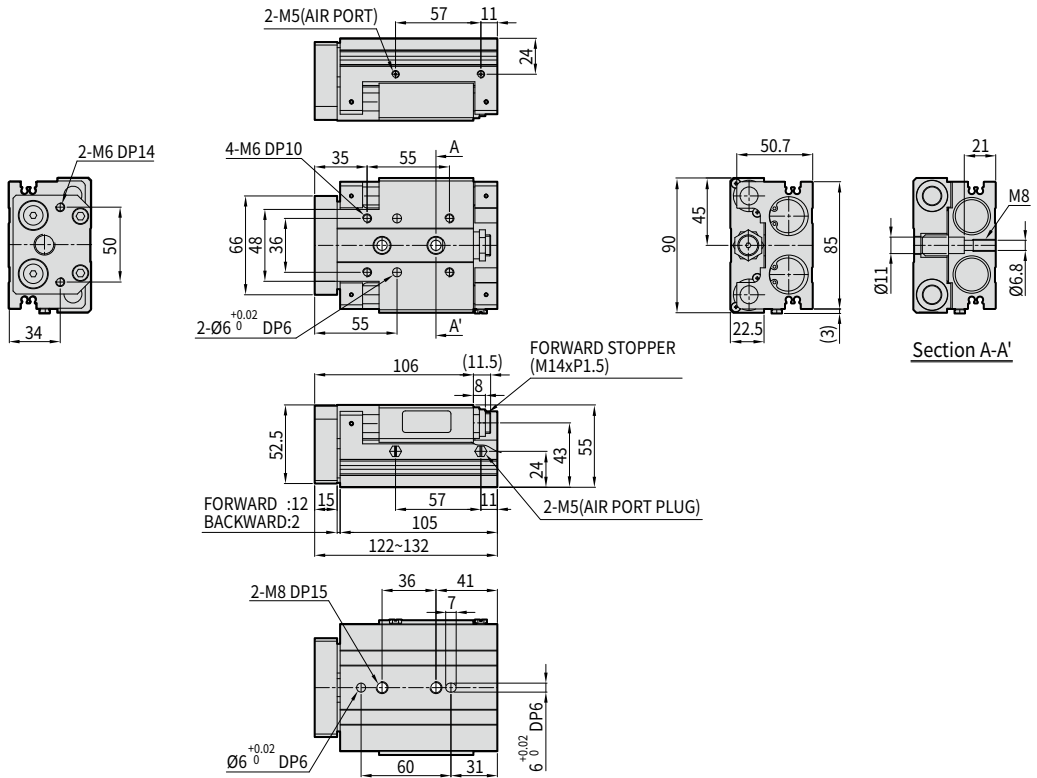

PBL25-10 전후진 Urethane Stopper

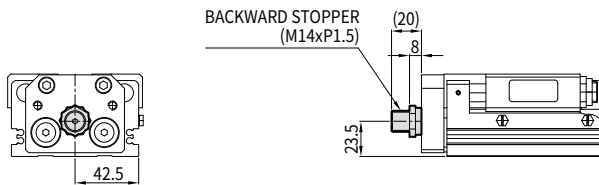

PBL25-10 Shock Absorber & Auto Switch 장착 예

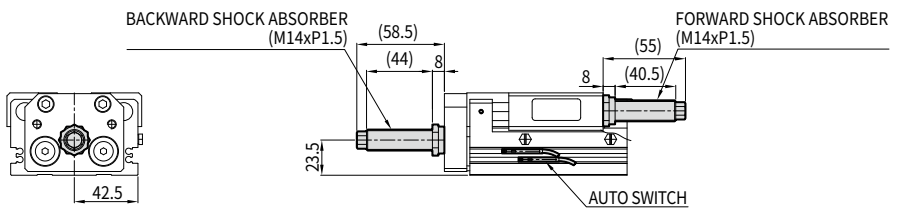

- 06
- 08
- 12
- 16
- 20
- 25
- 10
- 20
- 30
- 40
- 50
- 75
- 100

PBL25-20

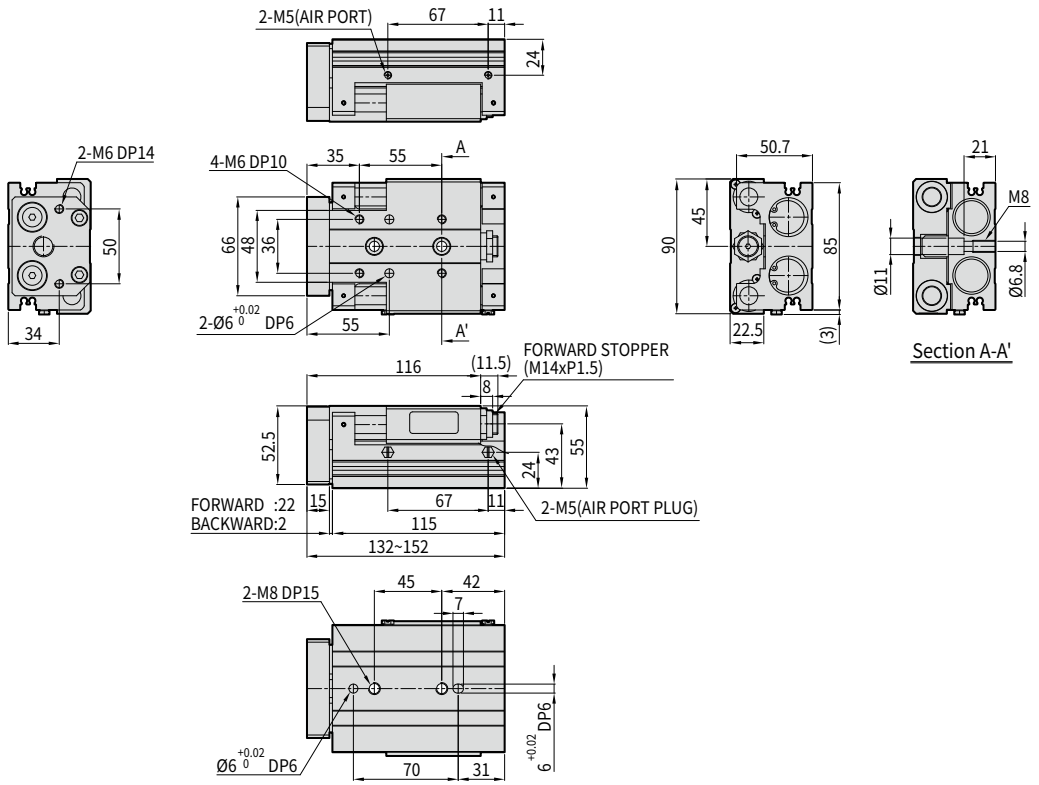

- BLOCK**
- PT
 - PB
 - PBM-N
 - PQG
 - PBL
 - PBF
 - PGL
 - PGC

PBL25-20 전후진 Urethane Stopper

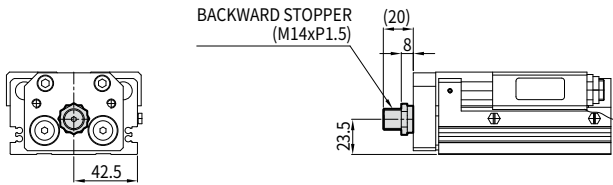

PBL25-20 Shock Absorber & Auto Switch 장착 예

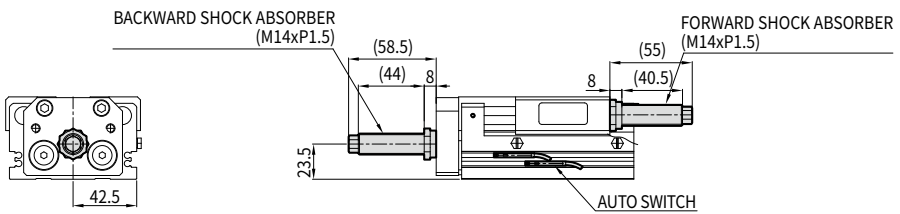

PBL Series

	06	08	12	16	20	25
10	20	30	40	50	75	100

PBL25-30

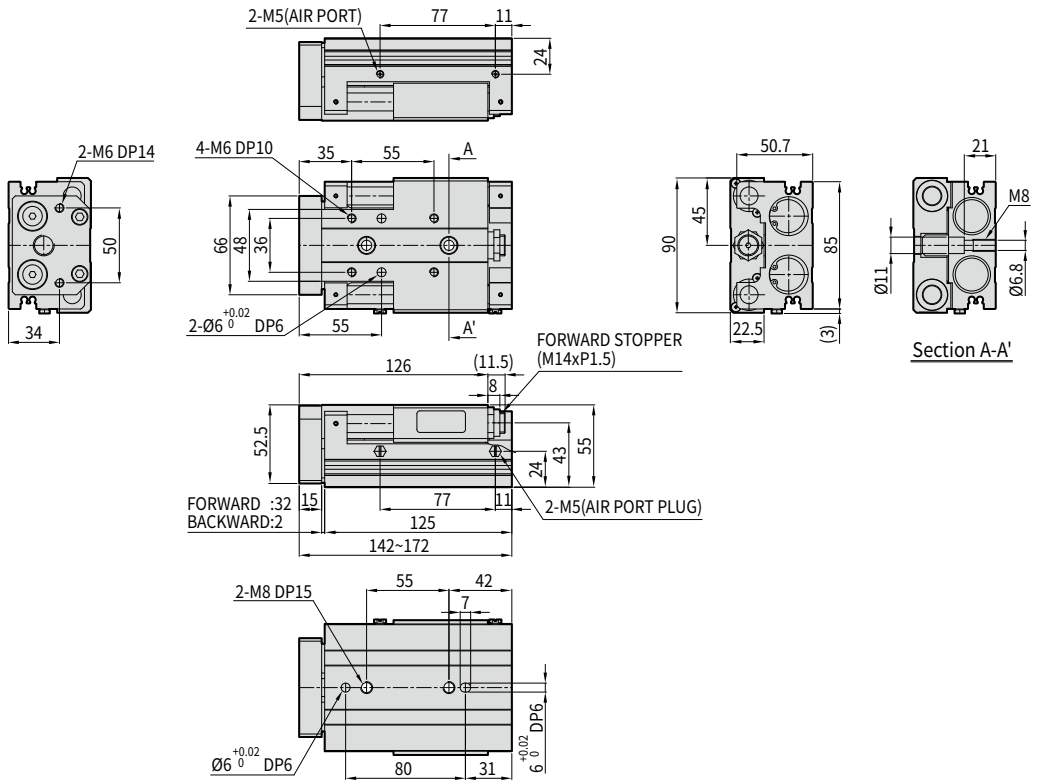

PBL25-30 전후진 Urethane Stopper

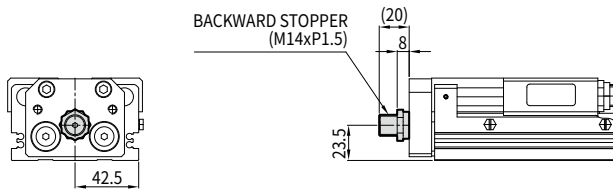

PBL25-30 Shock Absorber & Auto Switch 장착 예

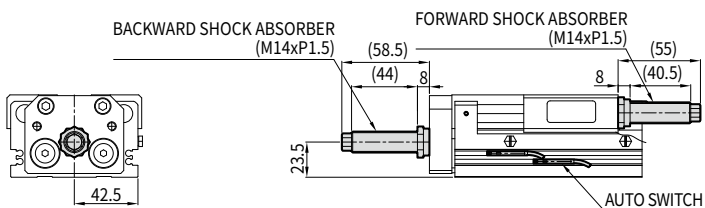

- 06
 - 08
 - 12
 - 16
 - 20
 - 25
- 10
 - 20
 - 30
 - 40
 - 50
 - 75
 - 100

PBL25-40

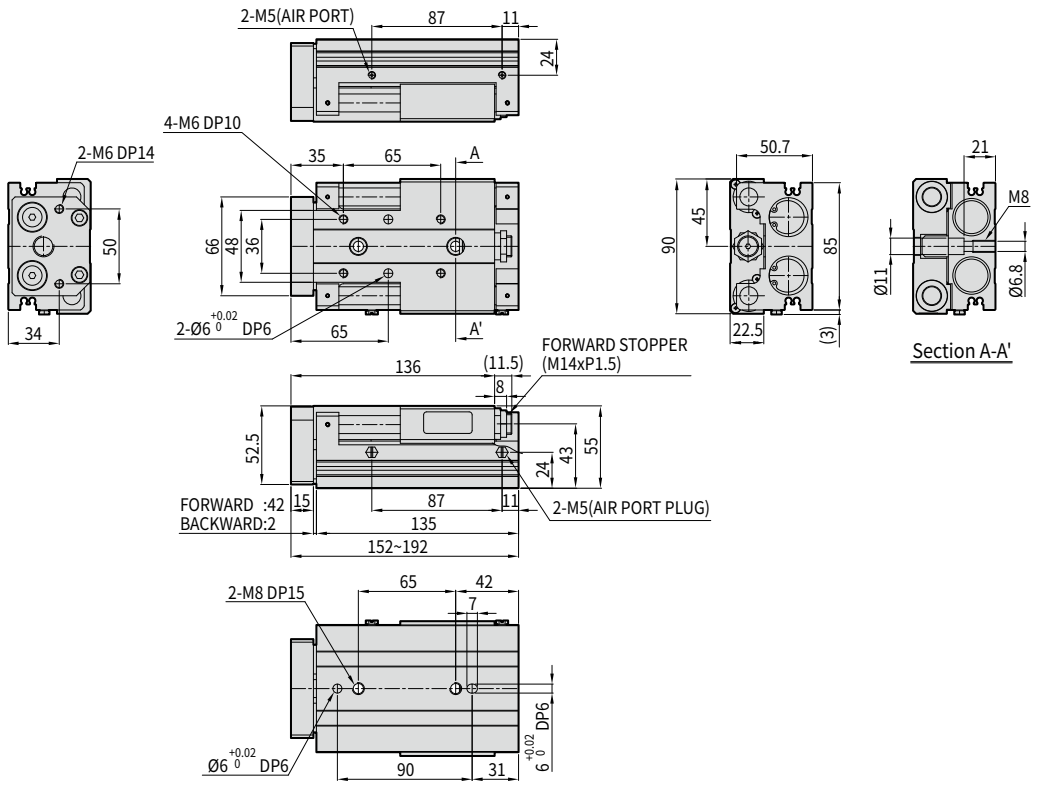

BLOCK

PT
PB
PBM-N
PQG
PBL
PBF
PGL
PGC

PBL25-40 전후진 Urethane Stopper

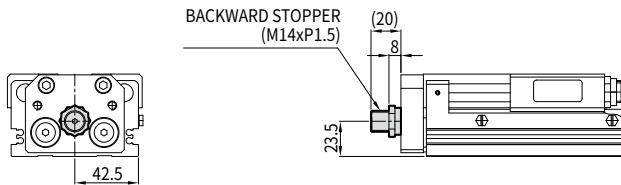

PBL25-40 Shock Absorber & Auto Switch 장착 예

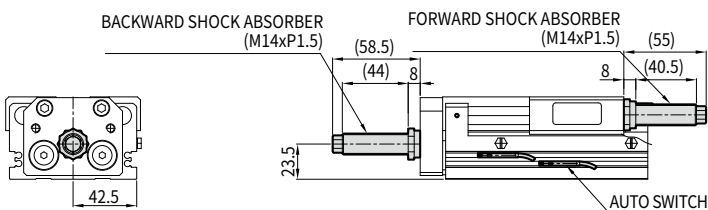

06	08	12	16	20	25	
10	20	30	40	50	75	100

PBL25-75

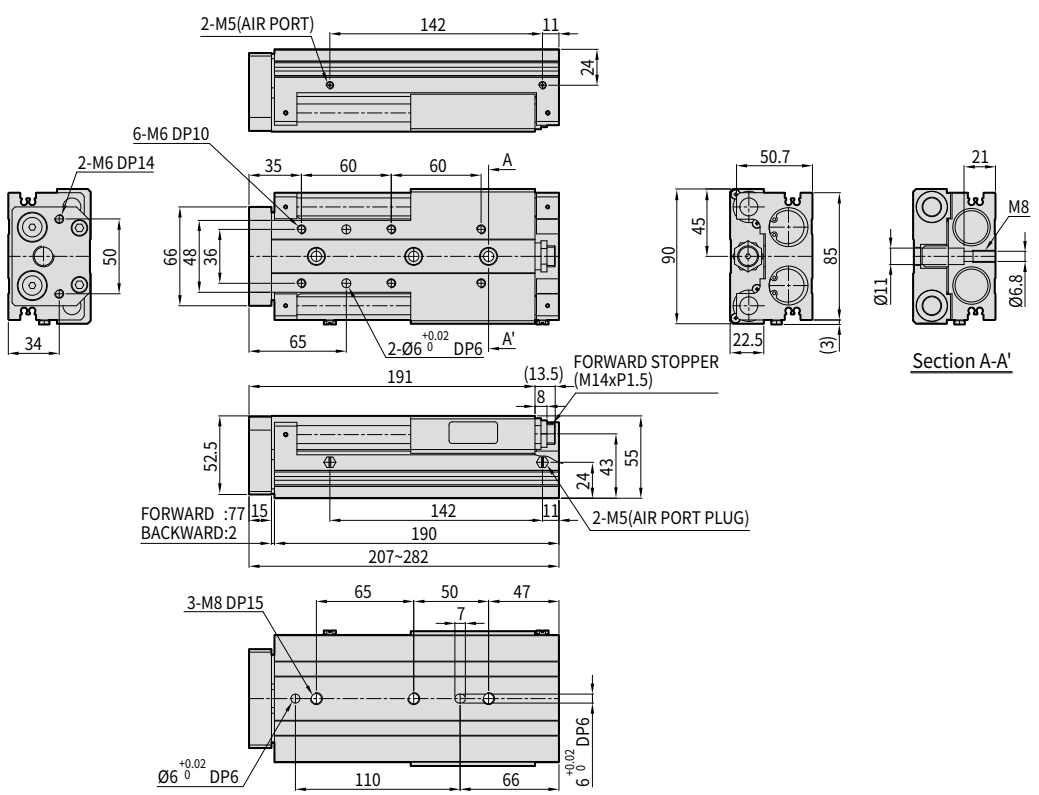

BLOCK

PT
PB
PBM-N
PQG
PBL
PBF
PGL
PGC

PBL25-75 전후진 Urethane Stopper

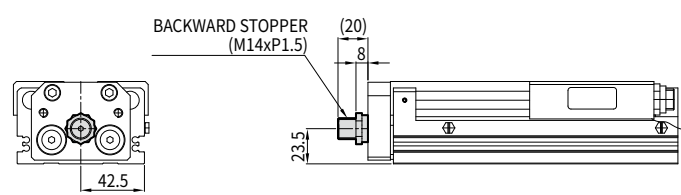

PBL25-75 Shock Absorber & Auto Switch 장착 예

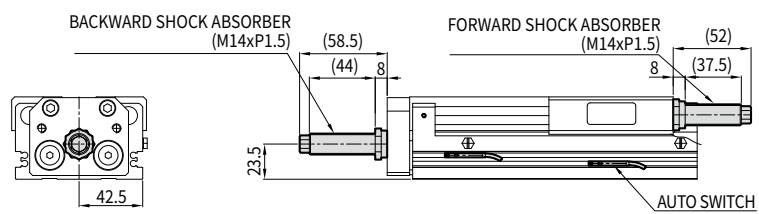

PBL Series

06	08	12	16	20	25	
10	20	30	40	50	75	100

PBL25-100

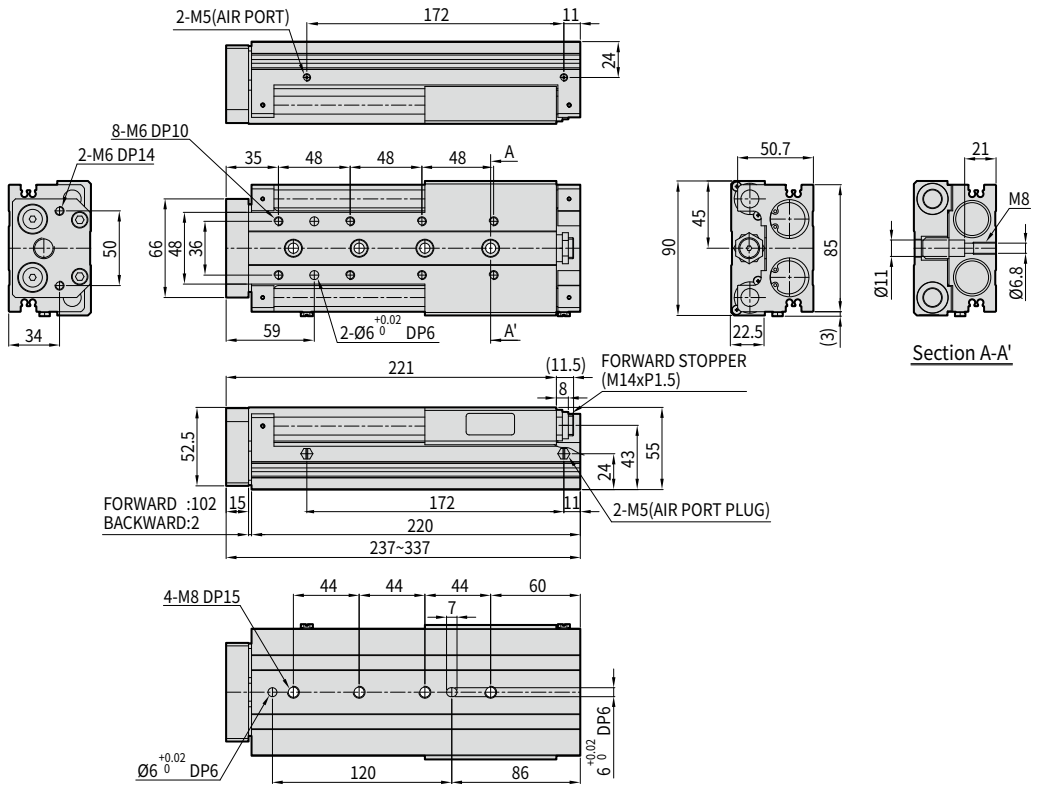

PBL25-100 전후진 Urethane Stopper

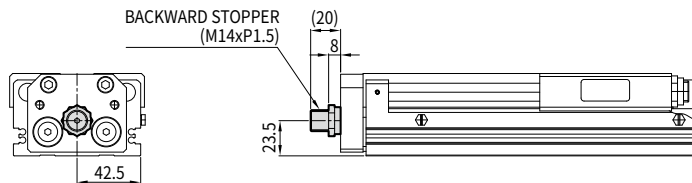

PBL25-100 Shock Absorber & Auto Switch 장착 예

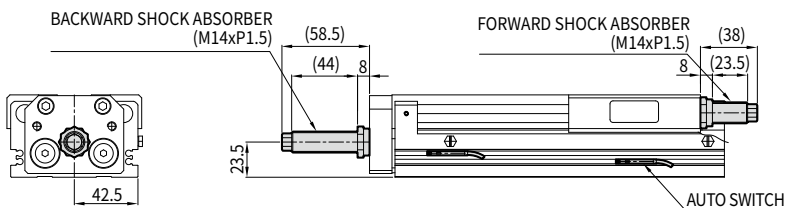

취부형태

1. 실린더 관통 구멍 이용형

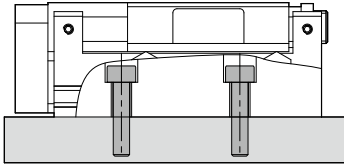

사 양	사용볼트	적정 체결 토크 (kgf·cm)	최대나사깊이 L (mm)
PBL06	M3×0.5	11	7.5
PBL08	M3×0.5	11	8
PBL12	M4×0.7	25	8.5
PBL16	M5×0.8	51	11.5
PBL20	M5×0.8	51	15
PBL25	M6×1	81	21

2. 실린더 몸체 탭 이용형

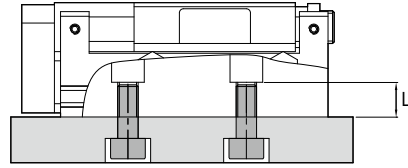

사 양	사용볼트	적정 체결 토크 (kgf·cm)	최대나사깊이 L (mm)
PBL06	M4×0.7	25	7.5
PBL08	M4×0.7	25	8
PBL12	M5×0.8	51	8.5
PBL16	M6×1	81	11
PBL20	M6×1	81	12
PBL25	M8×1.25	157	15

3. 테이블 탭 이용형

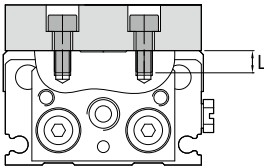

사 양	사용볼트	적정 체결 토크 (kgf·cm)	최대나사깊이 L (mm)
PBL06	M3×0.5	11	5
PBL08	M3×0.5	11	5
PBL12	M4×0.7	25	6
PBL16	M5×0.8	51	8
PBL20	M5×0.8	51	9
PBL25	M6×1	81	10

4. 플레이트 정면 탭 이용형

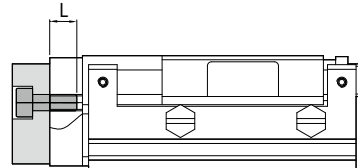

사 양	사용볼트	적정 체결 토크 (kgf·cm)	최대나사깊이 L (mm)
PBL06	M3×0.5	11	5
PBL08	M3×0.5	11	6
PBL12	M3×0.5	11	6
PBL16	M4×0.7	25	9
PBL20	M5×0.8	51	10
PBL25	M6×1	81	14

BLOCK

PT

PB

PBM-N

PQG

PBL

PBF

PGL

PGC